

brother

LH4-B817
LH4-B814 **Mark II**

本縫ボタン穴かがりミシン <LH4-B817>

LOCKSTITCH BUTTON HOLER <LH4-B814 **Mark II**>

STAPPSTICH-KNOPFLOCHNÄHMASCHINE <LH4-B814 **Mark II**>

MACHINE BOUTONNIERE-POINT NOUE <LH4-B814 **Mark II**>

MAQUINA DE OJALES <LH4-B814 **Mark II**>

パーツブック

PARTS BOOK

TEILEKATALOG

LIVRE DES PIECES

LIBRO DE REFERENCIA DE PIEZAS

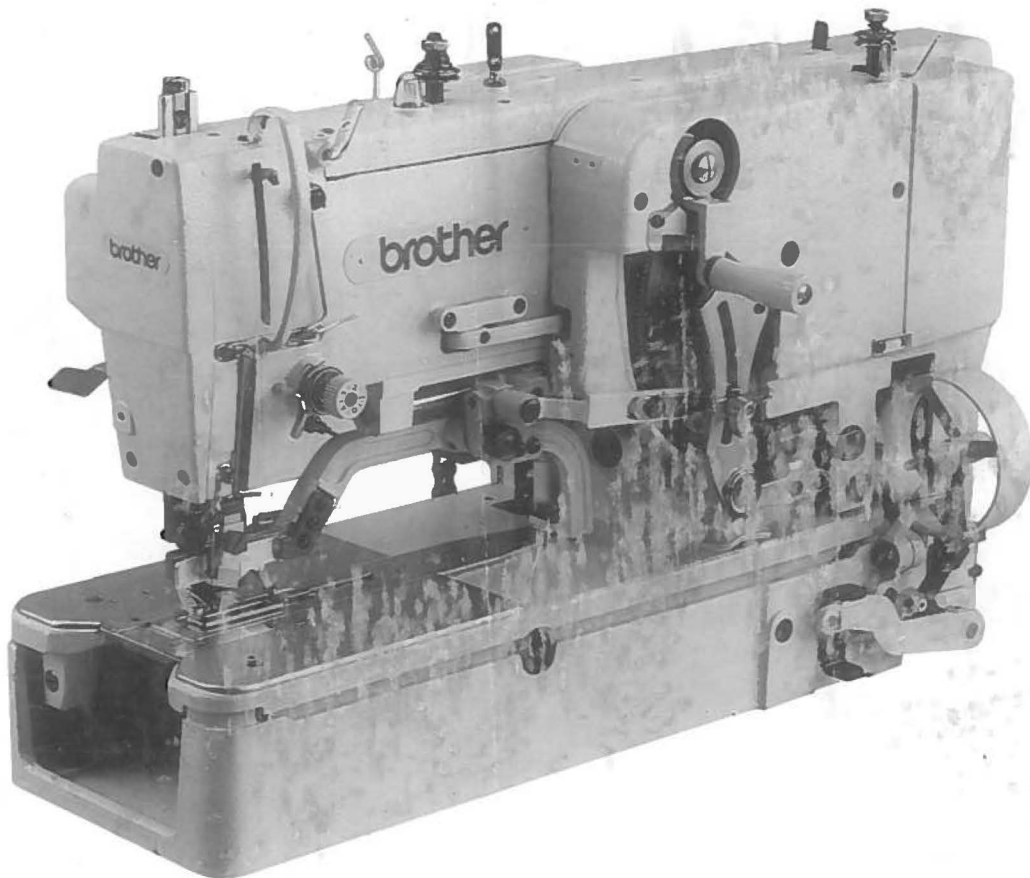

P817001

パーツブックご利用に際して

1. この本は、この本の表紙(正誤表の挿入されている場合は正誤表)に記載されているものと同じプレートが取り付けられているミシンのためのものです。
2. この本は、1993年6月のデータに基づいて作成されたものです。
3. 部品は予告なしに設計変更される場合があります。
4. 組単位で補給する部品は、 破線で示しております。
5. 部品コード欄が※となっている場合は、仕様別部品一覧表(73ページ)でお調べ下さい。

目 次

A. 主体関係	1
B. 針棒関係	5
C. 上軸関係	7
D. 針振関係	9
E. 停止関係	13
F. 減速関係	15
G. ベルト寄せ関係	15
H. 非常停止関係	17
J. テンションプーリ関係	17
K. 押エ関係	19
L. 糸切れ感知関係	19
M1~M3. 送り関係	21
N. カム伝導関係	29
P. カッター関係	31
Q. ヒモ案内関係 <-4>	33
R. タテ軸・下軸関係	35
S. 給油潤滑関係	37
T. 糸通シ関係	43
U. 糸巻関係	47
V1~V2. 上糸切り関係	49
W. 下糸切り関係	53
X1~X2. 付属装置関係(エアー式ワンペダル装置)	57
Y. 特別注文部品	63
Z1~Z2. 付属品関係	65
仕様別部品一覧表	73
回転数別モータプーリとVベルト組合せ	74
ゲージ部品一覧表	74~77
索引	78~89

Notes for using this parts book

1. This book is applicable to sewing machines which have the same plate number as shown on the cover of this book (or correction sheet).
2. This book was prepared based on information available in June 1993.
3. Parts are subject to changes in design without prior notice.
4. Parts supplied as complete assemblies are circled by a dotted line [] .
5. If the symbol ※ is found in the "Parts No." column, refer to the different parts list on page 73.

CONTENTS

A. Machine body	1	S. Lubrication	37
B. Needle bar mechanism	5	T. Threading mechanism	43
C. Upper Shaft Mechanism	7	U. Bobbin winder	47
D. Zigzag mechanism	9	V1. Upper thread trimmer mechanism	49
E. Clutch mechanism	13	V2. Upper thread trimmer mechanism	51
F. Power transmitter	15	W. Lower thread trimmer mechanism	53
G. Belt shift mechanism	15	X1. Attachment set (Pneumatic one-pedal device)	57
H. Emergency stop mechanism ..	17	X2. Attachment set (Pneumatic one-pedal device)	61
J. Tension pulley mechanism	17	Y. Option parts	63
K. Presser foot mechanism	19	Z1. Accessories	65
L. Thread breakage detector mechanism	19	Z2. Accessories	69
M1. Feed mechanism	21	DIFFERENT PARTS LIST ..	73
M2. Feed mechanism	25	MOTOR PULLEY AND V-BELT SELECTION	74
M3. Feed mechanism	27	GAUGE PARTS LIST	74~77
N. Feed cam mechanism	29	INDEX	78~89
P. Cutter mechanism	31		
Q. Gimp guide mechanism <-4> .	33		
R. Vertical shaft and lower shaft mechanism	35		

Hinweise zur Verwendung dieser Teileliste

1. Dieses Buch bezieht sich auf die Nähmaschinen mit derselben Kennungsnummer wie auf diesem Buchumschlag (oder auf dem Korrekturblatt).
2. Dieses Buch basiert auf den Informationen vom Juni 1993.
3. Modelländerungen sind vorbehalten.
4. Die Teile, die als kompletter Satz geliefert werden, sind mit einer gestrichelten Linie umrandet.
5. Dieses Zeichen ※ in der Spalte "Parts No. (Teil-nummer)" verweist auf die Gesonderte Stückliste auf Seite 73.

INHALTSVERZEICHNIS

A. Maschinengehäuse	1	S. Schmierung	37
B. Nadelstangenvorrichtung	5	T. Fadenführungsvorrichtung .	43
C. Obere Welle	7	U. Spuler	47
D. Zickzackvorrichtung	9	V1. Oberer Fadenabschneider ..	49
E. Kupplungsvorrichtung	13	V2. Oberer Fadenabschneider ..	51
F. Kraftübertragungsvorrichtung .	15	W. Unterer Fadenabschneider ..	53
G. Riemenumstellvorrichtung ...	15	X1. Anbausatz (Pneumatische	57
H. Abschaltvorrichtung	17	einpedalbedienung)	
J. Spannrolle	17	X2. Anbausatz (Pneumatische	61
K. Stoffdrückerfuß	19	einpedalbedienung)	
L. Fadenbruchfühler	19	Y. Sonderzubehör	63
M1. Transportvorrichtung	21	Z1. Zubehör	65
M2. Transportvorrichtung	25	Z2. Zubehör	69
M3. Transportvorrichtung	27	ZUBEHÖRLISTE	73
N. Transporteurkurve	29	AUSWAHL DER	74
P. Abschneidevorrichtung	31	RIEMENSCHLEIBEN UND	
Q. Schnurführung <-4>	33	ANTRIEBSRIEMEN	
R. Armwellen Und	35	LEHRENLISTE	74~77
Greifermechanismus		VERZEICHNIS	78~89

Notes sur l'utilisation de ce manuel de pièces détachées

1. Ce manuel est destiné aux machines à coudre ayant le même numéro de plaque montré sur la couverture de ce manuel (ou sur la feuille de corrections).
2. Ce manuel a été fait d'après les renseignements valables au mois de Juin 1993.
3. Les pièces peuvent être sujettes à des modifications sans préavis.
4. Les pièces fournies en tant qu'assemblages complets sont encadrées avec un trait pointillé [] .
5. Si le symbole ※ se trouve dans la colonne "Parts No. (N° de pièce)" veuillez la vous référer à la liste de pièces annexe page 73.

TABLE DES MATIERES

A. Corps de la machine	1	S. Lubrification	37
B. Mécanisme de la barre à aiguille et releveur de fil	5	T. Mécanisme de l'enfilage	43
C. Mécanisme de l'arbre supérieur	7	U. Mécanisme du bobineur	47
D. Mécanisme de zigzag	9	V1. Mécanisme de la coupe-fil supérieur	49
E. Mécanisme de l'embrayage	13	V2. Mécanisme de la coupe-fil supérieur	51
F. Mécanisme du transmetteur	15	W. Mécanisme de la coupe-fil inférieur	53
G. Mécanisme du changement de courroie	15	X1. Jeu d'accessoires (Pedale unique pneumatique)	57
H. Mécanisme de l'arrêt de secours	17	X2. Jeu d'accessoires (Pedale unique pneumatique)	61
J. Mécanisme de la poulie de tension	17	Y. Pièces en option	63
K. Mécanisme de pied presseur	19	Z1. Accessoires	65
L. Mécanisme du détecteur de cassure du fil	19	Z2. Accessoires	69
M1. Mécanisme de l'entraînement	21	LISTE DES PIÈCES ACCESSOIRES	73
M2. Mécanisme de l'entraînement	25	CHOIX DE LA POULIE DE MOTEUR ET DES COURROIES TRAPEZOIDALES	74
M3. Mécanisme de l'entraînement	27	LISTE DES PIÈCES D'ECARTEMENT	74~77
N. Mécanisme de la came déentraînement	29	INDEX	78~89
P. Mécanisme de la coupe	31		
Q. Mécanisme de guide-fil <-4>	33		
R. Mécanisme de l'axe de bras et de l'axe du crochet rotatif	35		

Notas para usar este Manual de Piezas

1. Este libro sirve para todas las máquinas de coser que llevan la misma placa de identificación que la que se puede ver en la tapa de este libro (o en la hoja de erratas).
2. Este libro ha sido compilado basándose en los datos de que se disponía en junio 1993.
3. Las piezas quedan sujetas a cambios de diseño sin aviso previo.
4. Las piezas suministradas como conjuntos completos se enmarcan con una línea punteada [] .
5. De haber un símbolo ※ junto al "Parts No. (Número de Pieza)", habrá que mirar la lista de piezas separada de la página 73.

INDICE

A. Cuerpo de la máquina	1	S. Lubricación	37
B. Mecanismo de la barra	5	T. Mecanismo del enhebrado . .	43
C. Mecanismo del eje superior . . .	7	U. Mecanismo del devanador de	47
D. Mecanismo del zigzag	9	la canilla	
E. Mecanismo de embrague	13	V1. Mecanismo de la recortadora	49
F. Mecanismo del transmisor de	15	de orillos superior	
potencia		V2. Mecanismo de la recortadora	51
G. Mecanismo del cambio correos	15	de orillos superior	
H. Mecanismo de parada de	17	W. Mecanismo de la recortadora	53
emergencia		de orillos inferior	
J. Mecanismo de la polea de	17	X1. Juego de fijación(Unidad de un	57
tensión		solo pedal neumático)	
K. Mecanismo de la prensa tela . . .	19	X2. Juego de fijación(Unidad de un	61
L. Mecanismo del sensor de cortes	19	solo pedal neumático)	
en el hilo		Y. Piezas opcionales	63
M1. Mecanismo de la alimentación .	21	Z1. Accesorios	65
M2. Mecanismo de la alimentación .	25	Z2. Accesorios	69
M3. Mecanismo de la alimentación .	27	LISTA DE PIEZAS	73
N. Mecanismo de la leva de	29	ACCESORIAS	
alimentación		ELECCION DE POLEA DE	74
P. Mecanismo de la corta	31	MOTOR Y CORREA	
Q. Mecanismo guía del hilo <-4>	33	TRAPEZOIDAL	
R. Mecanismo del eje del cangrejo	35	LISTA DE PIEZAS	74~77
y eje de la transmisión superior		CALIBRADORAS	
		INDICE	78~89

A . 主体関係/Machine body/Maschinengehäuse/Corps de la machine/Cuerpo de la máquina

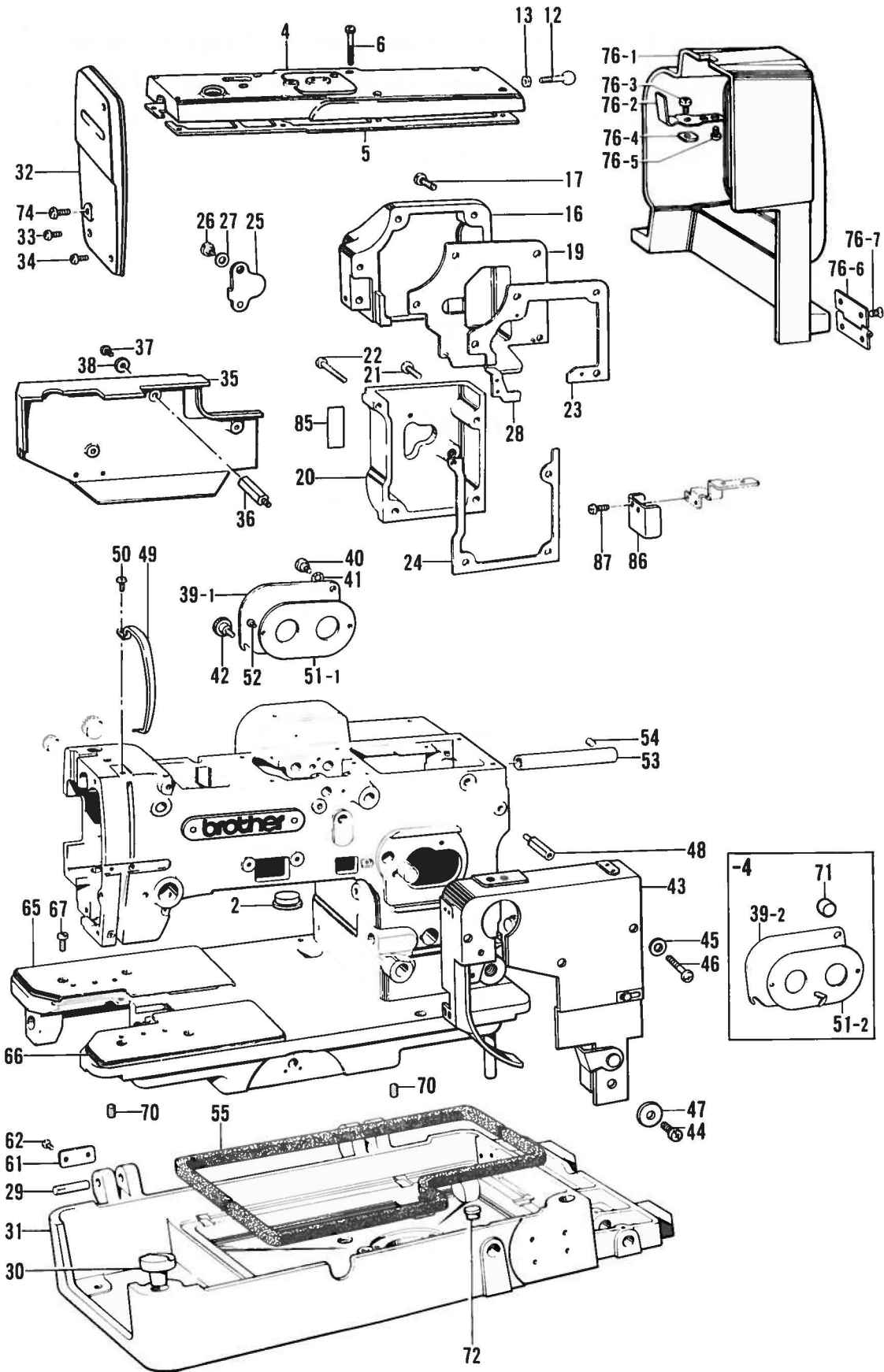

A . 主体関係/ Machine body / Maschinengehäuse / Corps de la machine / Cuerpo de la máquina

REF.NO.	CODE	Q'TY	ヒンメイ	NAME OF PARTS	RM
2	142743009	2	メクラセン	OIL CAP	
4	141243109	1	ウフフタ	TOP COVER	
5	141244100	1	ウフフタバツキン	TOP COVER PACKING	
6	S31808001	8	ナベコ437-40X25	SCREW, PAN M4.37-40X25	
12	141248001	1	ベルトカバーバネウケ	SPRING HOLDER	
13	105234003	1	ナツト4.37	NUT 4.37	
16	141249109	1	フクジクカバーU	SUB SHAFT COVER (U)	
17	062762012	4	ナベコ595-28X20	SCREW, PAN M5.95-28X20	
19	144946000	1	フクジクカバー	SUB SHAFT COVER	
20	143984009	1	フクジクカバーD	SUB SHAFT COVER (D)	
21	062762012	3	ナベコ595-28X20	SCREW, PAN M5.95-28X20	
22	S31808001	1	ナベコ437-40X25	SCREW, PAN M4.37-40X25	
23	141252000	1	バツキン	PACKING (LARGE)	
24	141254000	1	バツキン	PACKING (LARGE)	
25	143985101	1	チヨウセツマドフタ	ADJUST WINDOW COVER	
26	107321003	1	ダンネジ4.76	STUD SCREW 4.76	
27	107017002	1	ナミバネザガネ	WAVE SPRING WASHER	
28	142269000	1	バツキン	PACKING (SMALL)	
29	141257001	2	ミソツキピン	DOWEL PIN	
30	141258009	2	ベットクツシヨン	BED CUSHION	
31	141259009	1	ベットダイ	BED BASE	
32	S32977009	1	メンイタ	FACE PLATE	
33	062681412	2	ナベコ437-40X14	SCREW, PAN M4.37-40X14	
34	062681012	1	ナベコ437-40X10	SCREW, PAN M4.37-40X10	
35	S32979009	1	ソクメンカバー	FRAME SIDE COVER	
36	141262001	3	ソクメンカバートリツケボウ	STUD	
37	062681412	3	ナベコ437-40X14	SCREW, PAN M4.37-40X14	
38	025680132	3	ヒラザガネシヨウ4.37	WASHER, PLAIN S 4.37	
40	107321003	1	ダンネジ4.76	STUD SCREW 4.76	
41	107017002	1	ナミバネザガネ	WAVE SPRING WASHER	
42	129986001	1	ツマミネジ3.57	SCREW 3.57	
43	S32984009	1	カムカバー	CAM COVER	
44	062681212	1	ナベコ437-40X12	SCREW, PAN M4.37-40X12	
45	025680132	2	ヒラザガネシヨウ4.37	WASHER, PLAIN S 4.37	
46	S31808001	2	ナベコ437-40X25	SCREW, PAN M4.37-40X25	
47	116662003	1	ザガネ	WASHER	
48	141267001	1	カムカバートリツケボウ	STUD	
49	S33001009	1	テンビンカバー	THREAD TAKE-UP COVER	
50	062670512	1	ナベコ357-40X5	SCREW, PAN M3.57-40X5	
52	062670612	2	ナベコ357-40X6	SCREW, PAN M3.57-40X6	
53	141718001	1	イトキリレンカンLパイプ	THREADTRIMMING CONNECTING ROD (L) PIPE	
54	014760622	1	アナトメネジ5.95	SET SCREW, SOCKET (CP) M5.95	
55	114747001	2	オイルパンバツキン	OIL PAN PACKING	
61	142312001	2	トウブヒンジトメイタ	HEAD HOOK PLATE	
62	062680712	4	ナベコ437-40X7	SCREW, PAN M4.37-40X7	
70	013760712	2	トメネジ5.95クボミ	SET SCREW, (CP) M5.95	
72	117934009	1	メクラセン	OIL CAP	
74	062710616	1	-----	SCREW, PAN M4.76-32X6	
76	183852009	1	ベルトカバークミ	BELT COVER ASSY	
76-1	S32978009	1	ベルトカバー	BELT COVER	
76-2	141246001	1	ベルトカバーイタバネ	PLATE SPRING	
76-3	062680512	2	ナベコ437-40X5	SCREW, PAN M4.37-40X5	
76-4	141247001	1	ベルトカバーストツパー	BELT COVER STOPPER	
76-5	062680512	1	ナベコ437-40X5	SCREW, PAN M4.37-40X5	
76-6	107372001	2	ベルトカバーヒンヂクミ	BELT COVER HINGE ASSY	
76-7	107231002	4	サラネジ4.76	SCREW, FLAT M4.76	
85	S32982001	1	ハリフリハバセツメイラベル	LABEL	

A. 主体関係/Machine body/Maschinengehäuse/Corps de la machine/Cuerpo de la máquina

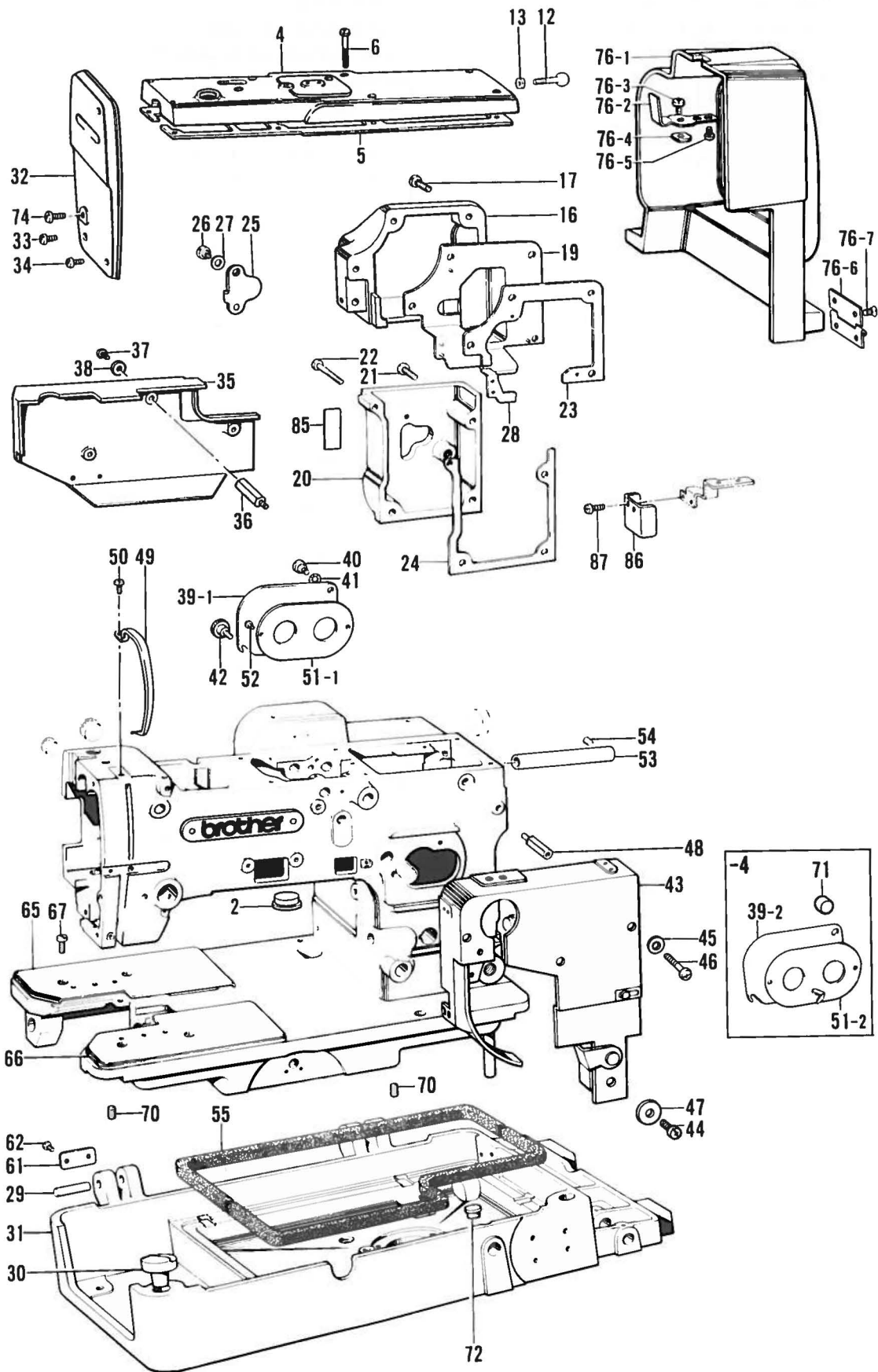

A . 主体関係/Machine body/Maschinengehäuse/Corps de la machine/Cuerpo de la máquina

REF.NO.	CODE	Q'TY	ヒンメイ	NAME OF PARTS	RM
39-1	141263104	1	<-2,-3,-5> ギヤケースフタ	GEAR CASE COVER	
51-1	141269001	1	ギヤボックスシキリイタ	GEAR SEPARATION PLATE	
86	S33004001	1	ハズシカネカバー	COVER	
87	062670412	2	ナベコ357-40X4	SCREW, PAN M3.57X4	
39-2	147202104	1	<-4> ギヤケースフタ	GEAR CASE COVER	
51-2	145345001	1	ギヤボックスシキリイタ	GEAR SEPARATION PLATE	
71	145342009	1	アームアナセン	OIL CAP	
65	143742001	1	<-2,-3,-4> ベッドカバーL	BED COVER (L)	
66	143741001	1	ベッドカバーR	BED COVER (R)	
67	107407003	4	シメネジ4.37	SCREW 4.37	

118-817-050

B. 針棒關係/Needle bar mechanism/Nadelstangenvorrichtung/
 Mécanisme de la barre à aiguille et releveur de fil/Mecanismo de la barra

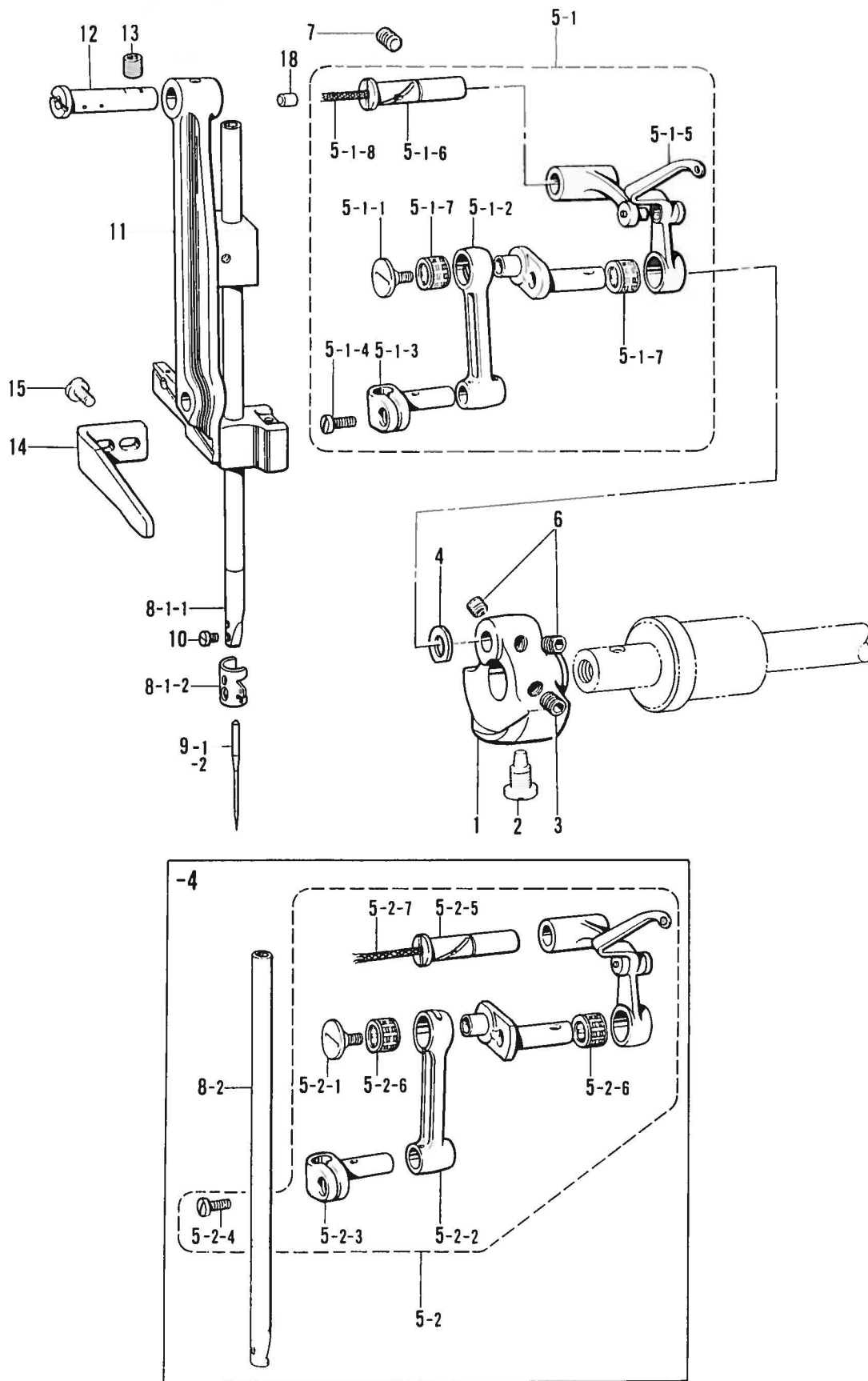

B. 針棒関係/Needle bar mechanism/Nadelstangenvorrichtung/
Mécanisme de la barre à aiguille et releveur de fil/Mecanismo de la barra

REF.NO.	CODE	Q'TY	ヒンメイ	NAME OF PARTS	RM
1	141290000	1	テンビンクランク	COUNTER WEIGHT	
2	100250001	1	シメネジ7.14	SCREW 7.14	
3	014770622	1	アナトメネジ6.35クボミ	SET SCREW, SOCKET (CP) M6.35	
4	110367001	1	ザガネ	WASHER	
6	014770622	2	アナトメネジ6.35クボミ	SET SCREW, SOCKET (CP) M6.35	
7	014770622	1	アナトメネジ6.35クボミ	SET SCREW, SOCKET (CP) M6.35	
10	140553102	1	アタマツキトメネジ3.18	SET SCREW 3.18	
11	142736001	1	ハリボウダイクミ	NEEDLE BAR BRACKET ASSY	
12	141295001	1	ハリボウダイササエジク	NEEDLE BAR BRACKET SUPPORT STUD	
13	014770622	1	アナトメネジ6.35クボミ	SET SCREW, SOCKET (CP) M6.35	
14	141296001	1	ハリボウダイアンナイ	NEEDLE BAR BRACKET GUIDE	
15	107407003	2	シメネジ4.37	SCREW 4.37	
18	140326009	1	ゴムセン	OIL CAP	

			<-2,-3,-5>		
5-1	S32986001	1	ハリボウレンカクミ	THREAD TAKE-UP LEVER ASSY	
5-1-1	145465001	1	シメネジ3.57L	SCREW 3.57 (L)	
5-1-2	S01143001	1	ハリボウクランクロッド	NEEDLE BAR CRANK ROD	
5-1-3	111237001	1	ハリボウダキ	NEEDLE BAR CLAMP	
5-1-4	140004001	1	シメネジ3.57	SCREW 3.57	
5-1-5	S32987001	1	テンビンタイクミ	THREAD TAKE-UP ASSY	
5-1-6	111468001	1	テンビンササエジク	THREAD TAKE-UP LEVER SUPPORT STUD	
5-1-7	116735000	2	ニードルベアリング	NEEDLE BEARING	
5-1-8	140430001	1	クミヒモ (L = 40)	WICK (L = 40)	
8-1	S32989001	1	ハリボウクミ	NEEDLE BAR ASSY	
8-1-1	S32990001	1	ハリボウ817	NEEDLE BAR (817)	
8-1-2	S33000001	1	ハリボウイトアンナイ	NEEDLE BAR THREAD GUIDE	
			<-4>		
5-2	145719101	1	ハリボウレンカクミ	THREAD TAKE-UP LEVER ASSY	
5-2-1	145465001	1	シメネジ3.57L	SCREW 3.57 (L)	
5-2-2	S01143001	1	ハリボウクランクロッド	NEEDLE BAR CRANK ROD	
5-2-3	111237001	1	ハリボウダキ	NEEDLE BAR CLAMP	
5-2-4	140004001	1	シメネジ3.57	SCREW 3.57	
5-2-5	111468001	1	テンビンササエジク	THREAD TAKE-UP LEVER SUPPORT STUD	
5-2-6	116735000	2	ニードルベアリング	NEEDLE BEARING	
5-2-7	140430001	1	クミヒモ (L = 40)	WICK (L = 40)	
8-2	146075001	1	ハリボウ	NEEDLE BAR	

			<-3>		
9-1	107415011	1	ミシンハリDPX5 (#11)	NEEDLE DPX5 (#11)	
			<-2,-4,-5>		
9-2	107415014	1	ミシンハリDPX5 (#14)	NEEDLE DPX5 (#14)	

C. 上軸関係/Upper Shaft Mechanism/Obere Welle/Mécanisme de l'arbre supérieur/
Mecanismo del eje superior

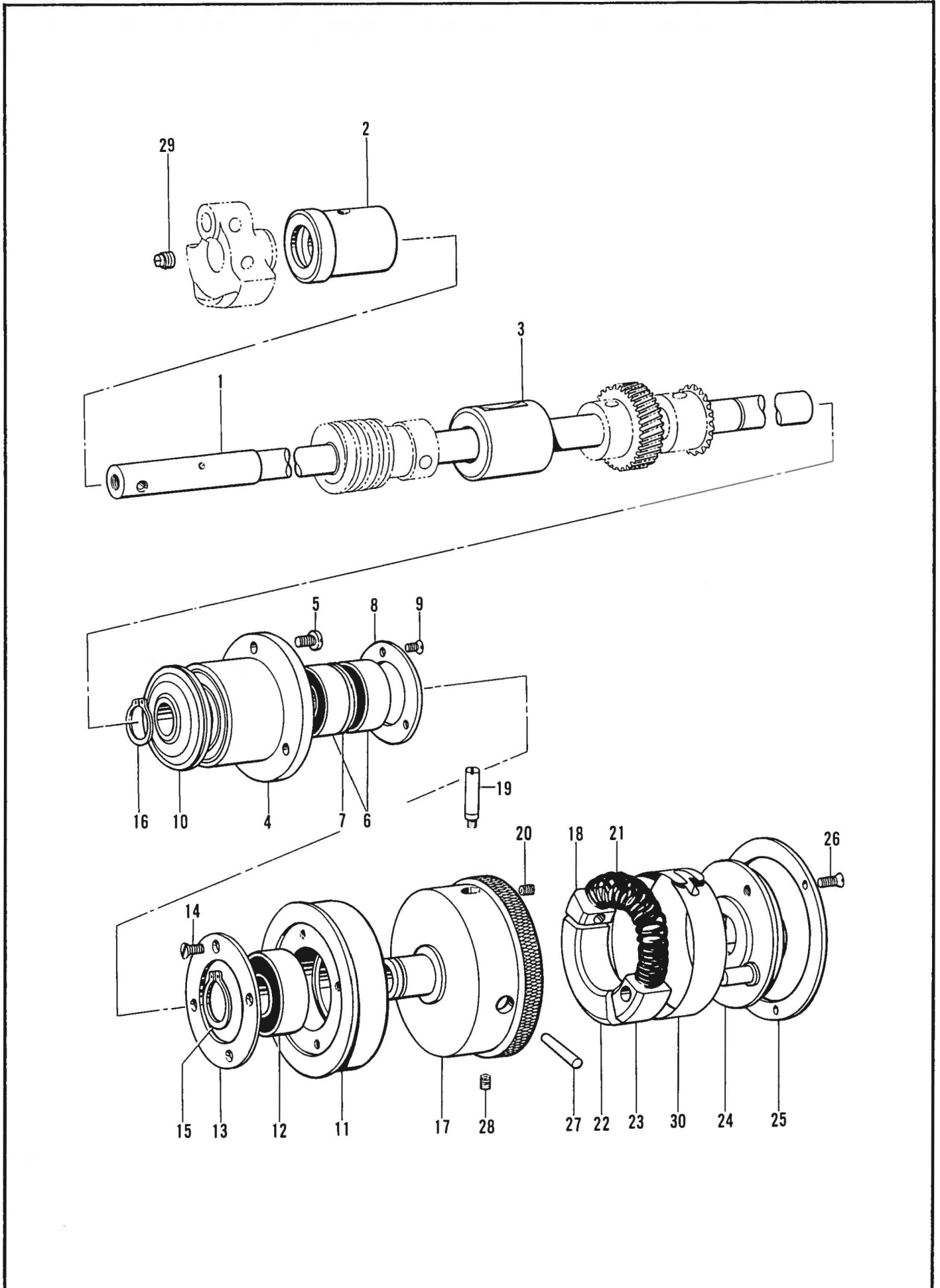

C. 上軸関係/Upper Shaft Mechanism/Obere Welle/Mécanisme de l'arbre supérieur/
Mecanismo del eje superior

REF.NO.	CODE	Q'TY	ヒンメイ	NAME OF PARTS	RM
1	141271001	1	ウワジク	UPPER SHAFT	
2	141272001	1	ウワジクメタルF	UPPER SHAFT BUSH (F)	
3	141273000	1	ウワジクメタルM	UPPER SHAFT BUSH (M)	
4	141274000	1	タマジクウケケース	BALL BEARING CASE	
5	062681212	3	ナベコ437-40X12	SCREW, PAN M4.37-40X12	
6	072620260	2	タマジクウケ6202VVC2	BALL BEARING 6202VVC2	
7	141275001	1	タマジクウケカラー	COLLAR	
8	141276001	1	タマジクウケフタS	BALL BEARING CAP (S)	
9	102843004	3	サラネジ3.57	SCREW, FLAT M3.57	
10	141277000	1	タマジクウケケースオイルキリ	OIL REJECTOR	
11	141278001	1	Pプーリ	IDLE PULLEY	
12	072600560	1	タマジクウケ6005VV	BALL BEARING 6005VV	
13	141279001	1	タマジクウケフタL	BALL BEARING CAP (L)	
14	102843004	4	サラネジ3.57	SCREW, FLAT M3.57	
15	048250142	1	トメワジクヨウC25	RETAINING RING, C25	
16	048150142	1	トメワジクヨウC15	RETAINING RING, C15	
17	141280001	1	プーリ	PULLEY	
18	141281001	1	プーリカクコマ	PULLEY SLIDE BLOCK	
19	141282001	1	プーリカクコマジク	SHAFT	
20	013670712	1	トメネジ3.57クボミ	SET SCREW, (CP) M3.57	
21	141283001	1	プーリカンシヨウバネ	SPRING	
22	141284000	1	プーリバネウケ	SPRING HOLDER	
23	141285001	1	プーリストツブカムカクコマ	PULLEY STOP CAM SLIDE BLOCK	
24	141286001	1	ストツブカムクミ	STOP CAM ASSY	
25	141289001	1	ストツブカムフタ	CAP FOR STOP CAM	
26	117348001	3	サラネジ3.57	SCREW, FLAT M3.57	
27	142297001	1	テーバビン	PIN, TAPER	
28	014770622	1	アナトメネジ6.35クボミ	SET SCREW, SOCKET (CP) M6.35	
29	101706001	1	トメネジ6.35	SET SCREW, M6.35	
30	142751001	1	プーリバネカバー	SPRING COVER	

D. 針振關係/Zigzag mechanism/Zickzackvorrichtung/Mécanisme de zigzag/
Mecanismo del zigzag

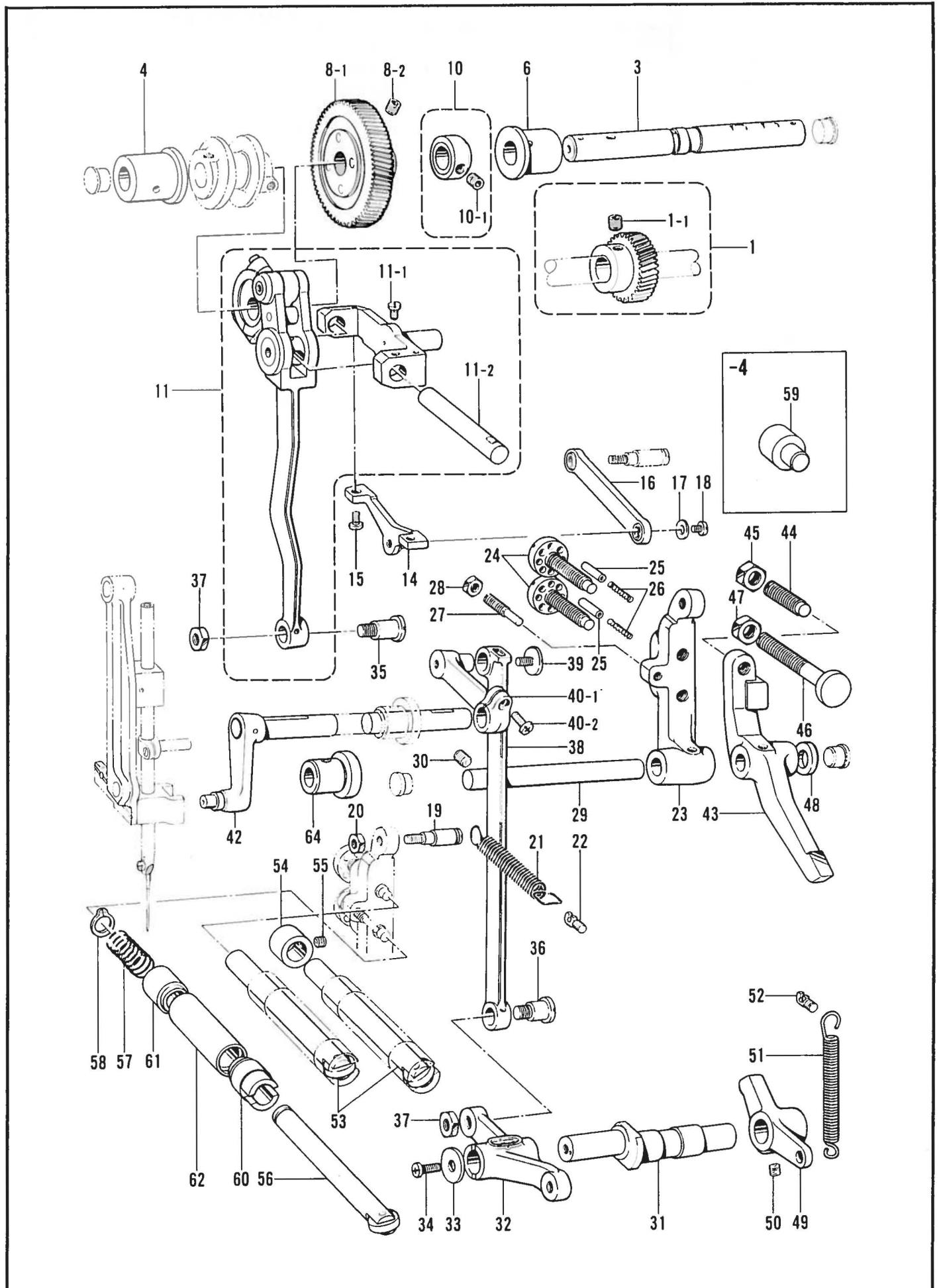

D. 針振関係/Zigzag mechanism/Zickzackvorrichtung/Mécanisme de zigzag/
Mecanismo del zigzag

REF.NO.	CODE	Q'TY	ヒンメイ	NAME OF PARTS	RM
1	183702001	1	ゲンソクギヤクミ	SPEED REDUCTION GEAR	
1-1	014770622	2	アナトメネジ6.35クボミ	SET SCREW, SOCKET (CP) M6.35	
3	141310001	1	フクジク	SUB SHAFT	
4	141311000	1	フクジクメタルF	SUB SHAFT BUSH (F)	
6	141312000	1	フクジクメタルB	SUB SHAFT BUSH (B)	
8	183703001	1	フクジクギヤクミ	SUB SHAFT GEAR UNIT	
8-1	141313101	1	フクジクギヤクミ	SUB SHAFT GEAR ASSY	
8-2	014770622	2	アナトメネジ6.35クボミ	SET SCREW, SOCKET (CP) M6.35	
10	181994001	1	ウワジクカラークミ	UPPER SHAFT SET COLLAR ASSY	
10-1	014760622	2	アナトメネジ5.95	SET SCREW, SOCKET (CP) M5.95	
11	147901001	1	ハリフリチヨウセツキカムクミ	ZIG ZAG ADJUST CAM ASSY	
11-1	104908002	1	アタマツキトメネジ	SET SCREW	
11-2	141326001	1	ロッドピン	ROD PIN	
14	141328000	1	チヨウセツキリンクジク	REGURATOR LINK SHAFT	
15	062680712	2	ナベコ437-40X7	SCREW, PAN M4.37-40X7	
16	141329001	1	ハリフリチヨウセツキリンククミ	ZIGZAG REGURATOR LINK ASSY	
17	102707002	1	ザガネ	WASHER	
18	062670612	1	ナベコ357-40X6	SCREW, PAN M3.57-40X6	
19	141332001	1	チヨウセツレバータマジク	PIN	
20	106588003	1	ナツト5.95	NUT 5.95	
21	141333001	1	チヨウセツレバーヒキバネ	SPRING,EXTENSION	
22	141334001	1	バネカケ	SPRING HOOK	
23	141335000	1	ハリフリチヨウセツレバー	ZIGZAG ADJUST LEVER	
24	141336001	2	ハリフリチヨウセツネジ	ADJUST SCREW	
25	141337001	2	ハリフリチヨウセツネジピン	PIN	
26	141338001	2	チヨウセツネジオシバネ	SPRING,COMPRESSION	
27	141339001	1	チヨウセツレバーストツバ	ADJUST LEVER STOPPER	
28	106588003	1	ナツト5.95	NUT 5.95	
29	141340001	1	チヨウセツレバージク	ZIGZAG ADJUST LEVER SHAFT	
30	013760612	1	トメネジ5.95クボミ	SET SCREW, (CP) M5.95	
31	141341001	1	ハリフリヘンシンジク	ZIGZAG ECCENTRIC SHAFT	
32	141342000	1	ハリフリヘンシンジクリンク	ZIGZAG ECCENTRIC SHAFT LINK	
33	149095001	1	ザガネ	WASHER	
34	062761212	1	ナベコ595-28X12	SCREW, PAN M5.95-28X12	
35	141344001	1	ダンネジ7.94	STUD SCREW 7.94	
36	141345001	1	ダンネジ7.94	STUD SCREW 7.94	
37	403388002	2	ナツト7.94	NUT 7.94	
38	141346001	1	ハリフリリンク	ZIGZAG CONNECTING ROD	
39	100511003	1	シメネジ4.76	SCREW 4.76	
40	183746001	1	ハリフリレバーAクミ	ZIGZAG CONNECTING LEVER (A) ASSY	
40-1	141347001	1	ハリフリレバーA	ZIGZAG CONNECTING LEVER (A)	
40-2	062711412	1	ナベコ4.76-32X14	SCREW, PAN M4.76-32X14	
42	141348001	1	ハリフリレバーBクミ	ZIGZAG CONNECTING LEVER (B) ASSY	
43	141354000	1	キジユンイチヘンカンレバー	ZIGZAG POSITION CHANGING LEVER	
44	141355001	1	Lキジユンチヨウセツネジ	ADJUST SCREW	
45	105812003	1	ナツト7.94	NUT 7.94	
46	141356001	1	Rキジユンチヨウセツネジ	ADJUST SCREW	
47	105812002	1	ナツト7.94	NUT 7.94	
48	158449001	1	ザガネ	WASHER	
49	141357000	1	ヘンカンレバーオサエ	CHANGING LEVER STOPPER	
50	014760622	2	アナトメネジ5.95	SET SCREW, SOCKET (CP) M5.95	
51	141358001	1	ヘンカンレバーヒキバネ	SPRING,EXTENSION	
52	141334001	1	バネカケ	SPRING HOOK	
54	141351001	1	セツトカラー	SET COLLAR	
55	014770622	1	アナトメネジ6.35クボミ	SET SCREW, SOCKET (CP) M6.35	
56	141659001	1	カントメオシボウクミ	BAR TACK CONNECTING SHAFT	
57	141363001	1	カントメオシボウオシバネ	SPRING,COMPRESSION	
58	048110142	1	トメワジクヨウC11	RETAINING RING, C11	
64	147155000	1	ハリフリジクメタル	ZIGZAG CONNECTING LEVER SHAFT BUSH	

D. 針振關係/Zigzag mechanism/Zickzackvorrichtung/Mécanisme de zigzag/
Mecanismo del zigzag

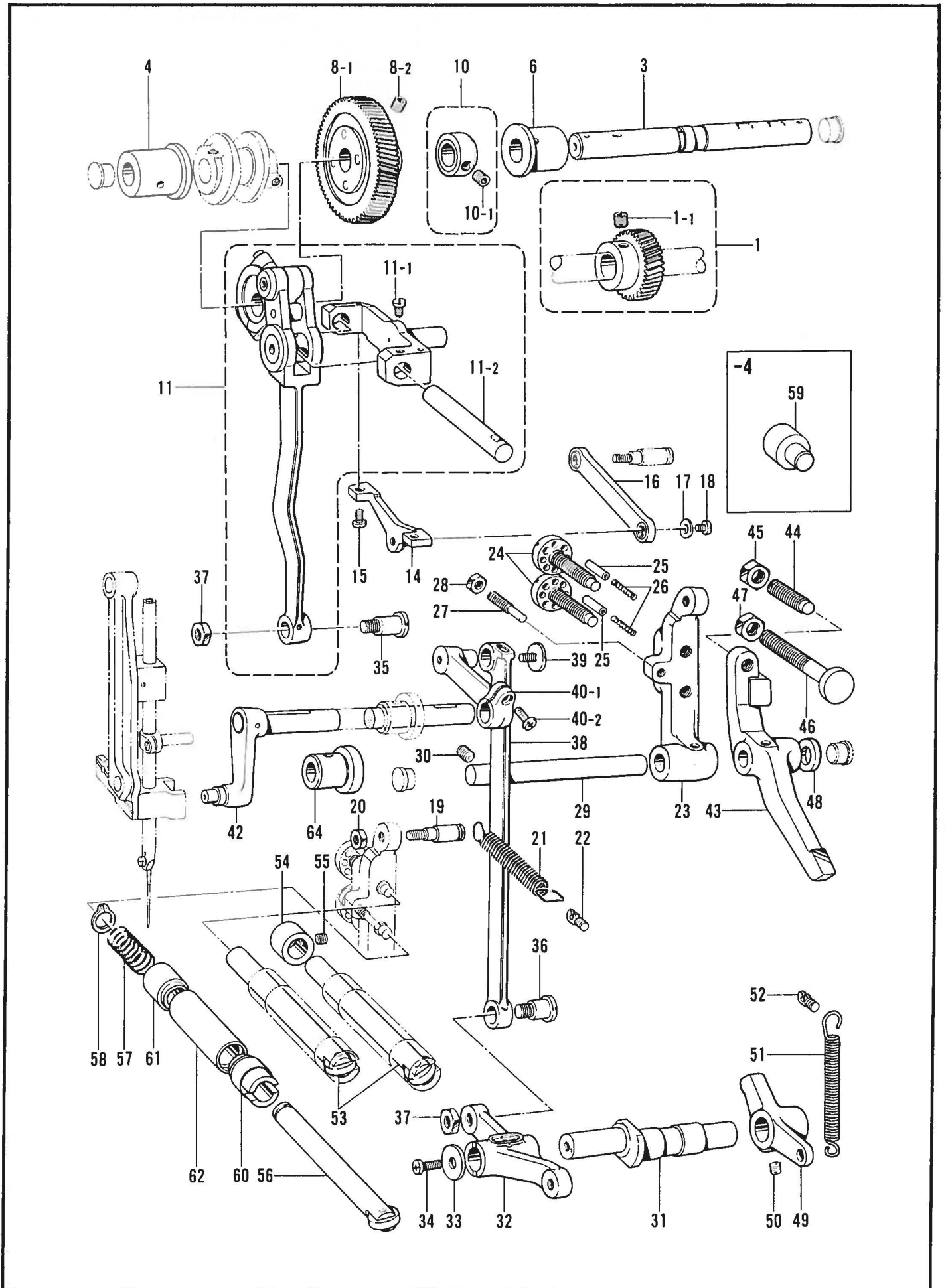

D. 針振関係/Zigzag mechanism/Zickzackvorrichtung/Mécanisme de zigzag/
Mecanismo del zigzag

REF.NO.	CODE	Q'TY	ヒンメイ	NAME OF PARTS	RM
			<-4>		
53	141359001	1	ハリフリオシボウクミ	ZIGZAG CONNECTING SHAFT	
59	145344001	1	ダンジク	STUD SHAFT	
60	141716000	2	ハリフリオシボウメタルR	ZIGZAG CONNECTING SHAFT BUSH (R)	
61	141365000	2	ハリフリオシボウメタルL	ZIGZAG CONNECTING SHAFT BUSH (L)	
62	141366001	2	ハリフリオシボウパイプ	COLLAR	
			<-2,-3,-5>		
53	141359001	2	ハリフリオシボウクミ	ZIGZAG CONNECTING SHAFT	
60	141716000	3	ハリフリオシボウメタルR	ZIGZAG CONNECTING SHAFT BUSH (R)	
61	141365000	3	ハリフリオシボウメタルL	ZIGZAG CONNECTING SHAFT BUSH (L)	
62	141366001	3	ハリフリオシボウパイプ	COLLAR	

118-817-110

E. 停止關係/Clutch mechanism/Kupplungsvorrichtung/
 Mécanisme de l'embrayage/Mecanismo de embrague

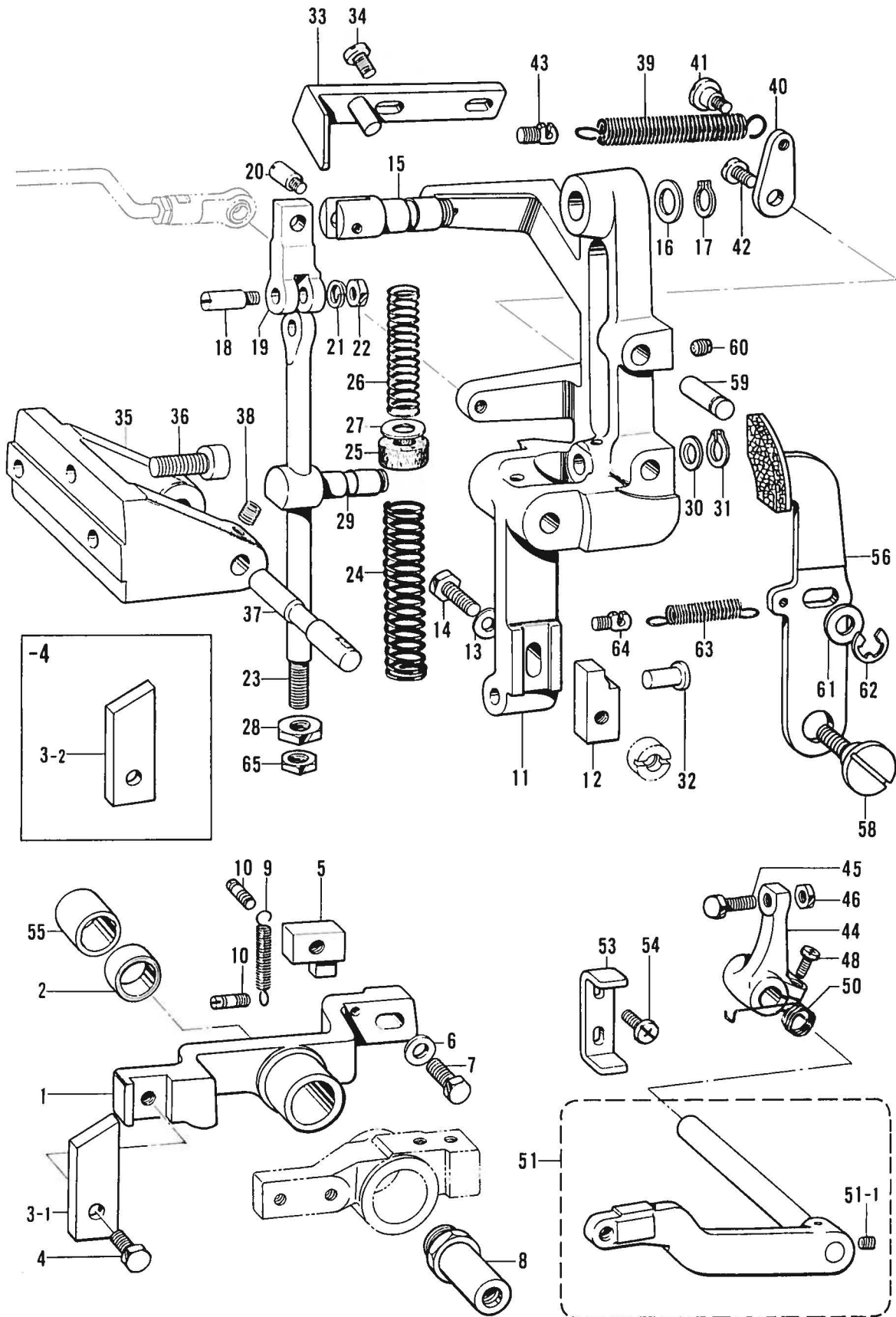

E. 停止関係/Clutch mechanism/Kupplungsvorrichtung/Mécanisme de l'embrayage/Mecanismo de embrague

REF.NO.	CODE	Q'TY	ヒンメイ	NAME OF PARTS	RM
1	141546001	1	テイシレバー	STOP LEVER	
2	142372000	1	DUブシユ	(DU) BUSH	
3-1	141547001	1	テイシカムヘンB <-2,-3,-5>	STOP CAM SEGMENT (B) <-2,-3,-5>	
3-2	145442001	1	テイシカムヘンB <-4>	STOP CAM SEGMENT (B) <-4>	
4	017761412	1	ボルトM5.95X14	BOLT, M5.95X14	
5	141548001	1	クラツチツメA	CLUTCH CLAW (A)	
6	118735002	1	ザガネ	WASHER	
7	017781412	1	ボルトM6.35X14	BOLT, M6.35X14	
8	141618001	1	テイシレバージク	EMERGENCY STOP LEVER SHAFT	
9	141549001	1	テイシレバーヒキバネ	SPRING, EXTENSION	
10	141550001	2	テイシレバーバネカケ	SPRING HOOK	
11	146041002	1	クラツチレバー	CLUTCH LEVER	
12	141553001	1	クラツチツメB	CLUTCH CLAW (B)	
13	118735002	1	ザガネ	WASHER	
14	017782512	1	ボルトM6.35X25	BOLT, M6.35X25	
15	142667101	1	クラツチストツバササエ	CLUTCH STOPPER SUPPORT	
16	025100132	1	ヒラザガネシヨウ10	WASHER, PLAIN S 10	
17	048100142	1	トメワジクヨウC10	RETAINING RING, C10	
18	115544001	1	クラツチストツバササエジク	CLUTCH STOPPER SUPPORT SHAFT	
19	115545001	1	クラツチストツバ	CLUTCH STOPPER	
20	115546001	1	クラツチストツバジク	CLUTCH STOPPER STUD	
21	028050240	1	バネザガネ2-5	WASHER, SPRING 2-5	
22	021710202	1	ナツト2シユ4.76	NUT, 2 M4.76	
23	141554001	1	ストツババネジク	SPRING SHAFT	
24	147639001	1	ストツバオシバネC	SPRING, COMPRESSION (C)	
25	115550001	1	フェルト	FELT	
26	115551001	1	ストツバオシバネB	SPRING, COMPRESSION (B)	
27	025100132	1	ヒラザガネシヨウ10	WASHER, PLAIN S 10	
28	021860202	1	ナツト2シユ9.52	NUT, 2 M9.52	
29	115552001	1	チヨウセツバネジクダキ	SHAFT CLAMP	
30	025100132	1	ヒラザガネシヨウ10	WASHER, PLAIN S 10	
31	048100142	1	トメワジクヨウC10	RETAINING RING, C10	
32	141555001	1	クラツチレバーピン	PIN	
33	141556101	1	ベルトヨセウ	BELT SHIFTER (U)	
34	062761012	2	ナベコ595-28X10	SCREW, PAN M5.95-28X10	
35	141557002	1	クラツチレバードライ	CLUTCH LEVER BRACKET	
36	018082522	3	アナボルト8X25	BOLT, SOCKET M8X25	
37	141558001	1	クラツチレバージク	CLUTCH LEVER SHAFT	
38	014770622	1	アナトメネジ6.35クボミ	SET SCREW, SOCKET (CP) M6.35	
39	141559001	1	クラツチモドシヒキバネ	SPRING, EXTENSION	
40	115558002	1	バネチヨウセツイタ	ADJUST PLATE	
41	115559002	1	ダンネジ4.76	STUD SCREW 4.76	
42	062761012	1	ナベコ595-28X10	SCREW, PAN M5.95-28X10	
43	141334001	1	バネカケ	SPRING HOOK	
44	146955004	1	クラツチシドウレバー	CLUTCH STARTING LEVER	
45	115585001	1	ボルト7.94	BOLT, M7.94	
46	152997001	1	ナツト7.94	NUT 7.94	
48	062711412	2	ナベコ4.76-32X14	SCREW, PAN M4.76-32X14	
50	141562101	1	シドウレバーモドシバネ	SPRING	
51	150538009	1	シドウレバーテコクミ	STARTING LIFT LEVER ASSY	
51-1	014770622	1	アナトメネジ6.35クボミ	SET SCREW, SOCKET (CP) M6.35	
53	141564001	1	シドウレバーテコストツバ	STARTING LEVER STOPPER	
54	062761212	2	ナベコ595-28X12	SCREW, PAN M5.95-28X12	
55	142373000	1	DUブシユ	(DU) BUSH	
56	142755001	1	ブレーキレバークミ	BRAKE LEVER ASSY	
58	141953001	1	ダンネジ7.14	STUD SCREW 7.14	
59	142214001	1	ブレーキレバージク	BRAKE LEVER PIN	
60	014760622	1	アナトメネジ5.95	SET SCREW, SOCKET (CP) M5.95	
61	107153002	1	ザガネ	WASHER	
62	048070342	1	トメワE7	RETAINING RING, E7	
63	142771001	1	ブレーキヒキバネ	SPRING, EXTENSION	
64	141334001	1	バネカケ	SPRING HOOK	
65	100075004	1	ナツト9.52	NUT 9.52	

F. 減速関係/Power transmitter/Kraftübertragungsvorrichtung/
 Mécanisme du transmetteur/Mecanismo del transmisor de potencia

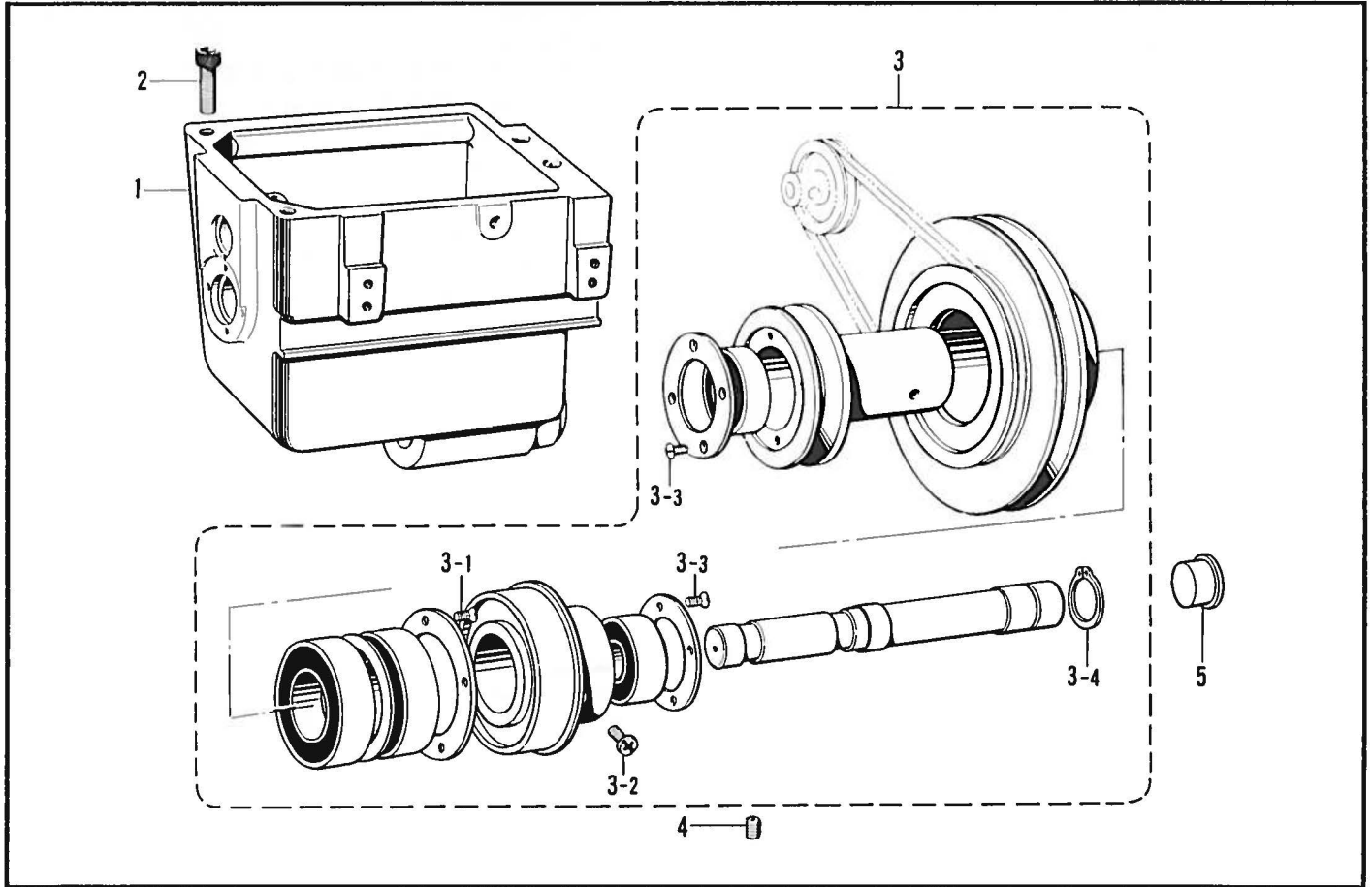

118-817-112

G. ベルト寄せ関係/Belt shift mechanism/Riemenumstellvorrichtung/
 Mécanisme du changement de courroie/Mecanismo del cambio correos

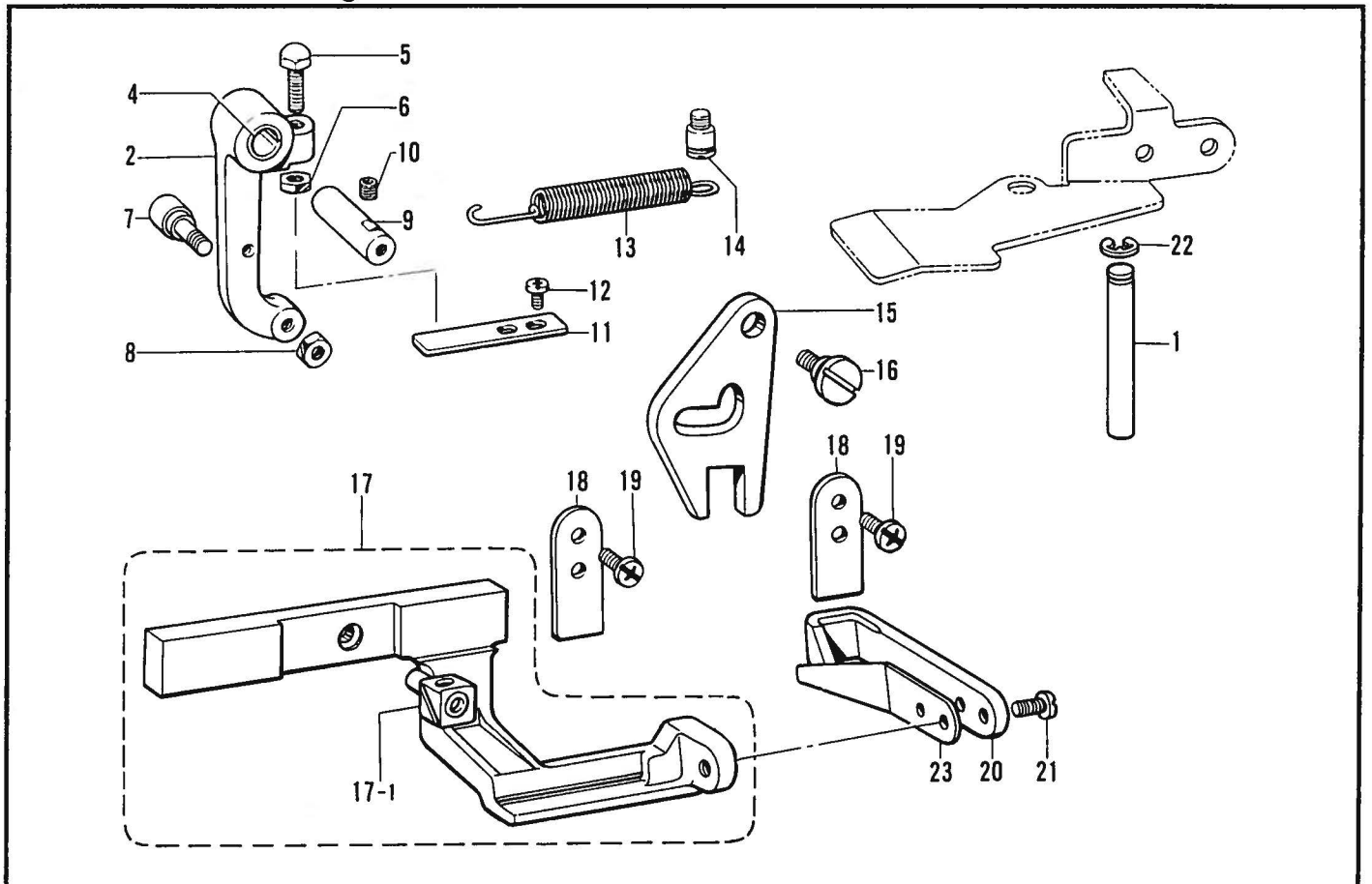

118-817-113

F. 減速関係/Power transmitter/Kraftübertagungsrichtung/
Mécanisme du transmetteur/Mecanismo del transmisor de potencia

REF.NO.	CODE	Q'TY	ヒンメイ	NAME OF PARTS	RM
1	147222109	1	トランスミッタダイ	TRANSMITTER BASE	
2	018082522	3	アナボルト8X25	BOLT, SOCKET M8X25	
3	141566001	1	トランスミッタクミ	TRANSMITTER ASSY	
3-1	S01695001	4	サラネジ3.18X8	SCREW, FLAT M3.18X8	
3-2	062711412	2	ナベコ4.76-32X14	SCREW, PAN M4.76-32X14	
3-3	S01695001	8	サラネジ3.18X8	SCREW, FLAT M3.18X8	
3-4	048200142	1	トメワジクヨウC20	RETAINING RING, C20	
4	013781012	2	トメネジ6.35クボミ	SET SCREW, (CP) M6.35	
5	111937009	1	メクラセン	OIL CAP	

118-817-112

G. ベルト寄せ関係/Belt shift mechanism/Riemenumstellvorrichtung/
Mécanisme du changement de courroie/Mecanismo del cambio correos

REF.NO.	CODE	Q'TY	ヒンメイ	NAME OF PARTS	RM
1	141574001	1	ベルトヨセボウ	BELT SHIFT BAR	
2	141575001	1	ベルトヨセレバー	BELT SHIFT LEVER	
4	142373000	2	DUブシユ	(DU) BUSH	
5	115585001	1	ボルト7.94	BOLT, M7.94	
6	152997001	1	ナツト7.94	NUT 7.94	
7	141576001	1	ベルトヨセコロクミ	BELT SHIFT ROLLER ASSY	
8	021750102	1	1シユナツト556-32	NUT, 1 M556-32	
9	141579001	1	ベルトヨセレバージク	BELT SHIFT LEVER STUD	
10	014770622	1	アナトメネジ6.35クボミ	SET SCREW, SOCKET (CP) M6.35	
11	141580001	1	ベルトヨセレバーストツバ	BELT SHIFT LEVER STOPPER	
12	062680812	2	ナベコ437-40X8	SCREW, PAN M4.37-40X8	
13	141581001	1	ベルトヨセレバーヒキバネ	SPRING, EXTENSION	
14	141472002	1	シタイトキリレバーバネカケ	SPRING HOOK	
15	141582001	1	ベルトヨセカム	BELT SHIFT CAM	
16	141583001	1	ダンネジ6.35	STUD SCREW 6.35	
17	141584001	1	ベルトヨセタイクミ	BELT SHIFT BRACKET ASSY	
17-1	141586001	1	ベルトヨセカクコマクミ	BELT SHIFT SLIDE BLOCK ASSY	
18	141588001	2	ベルトヨセタイアンナイ	BELT SHIFT GUIDE	
19	062680812	4	ナベコ437-40X8	SCREW, PAN M4.37-40X8	
20	141589001	1	ベルトヨセD	BELT SHIFTER (D)	
21	062711012	2	ナベコ476-32X10	SCREW, PAN M4.76-32X10	
22	048070342	1	トメワE7	RETAINING RING, E7	
23	145931001	1	ベルトヨセDバネ	SPRING, PLATE	

118-817-113

H. 非常停止関係/Emergency stop mechanism/Abschaltvorrichtung/
Mécánisme de lárrêt de secours/Mecanismo de parada de emergencia

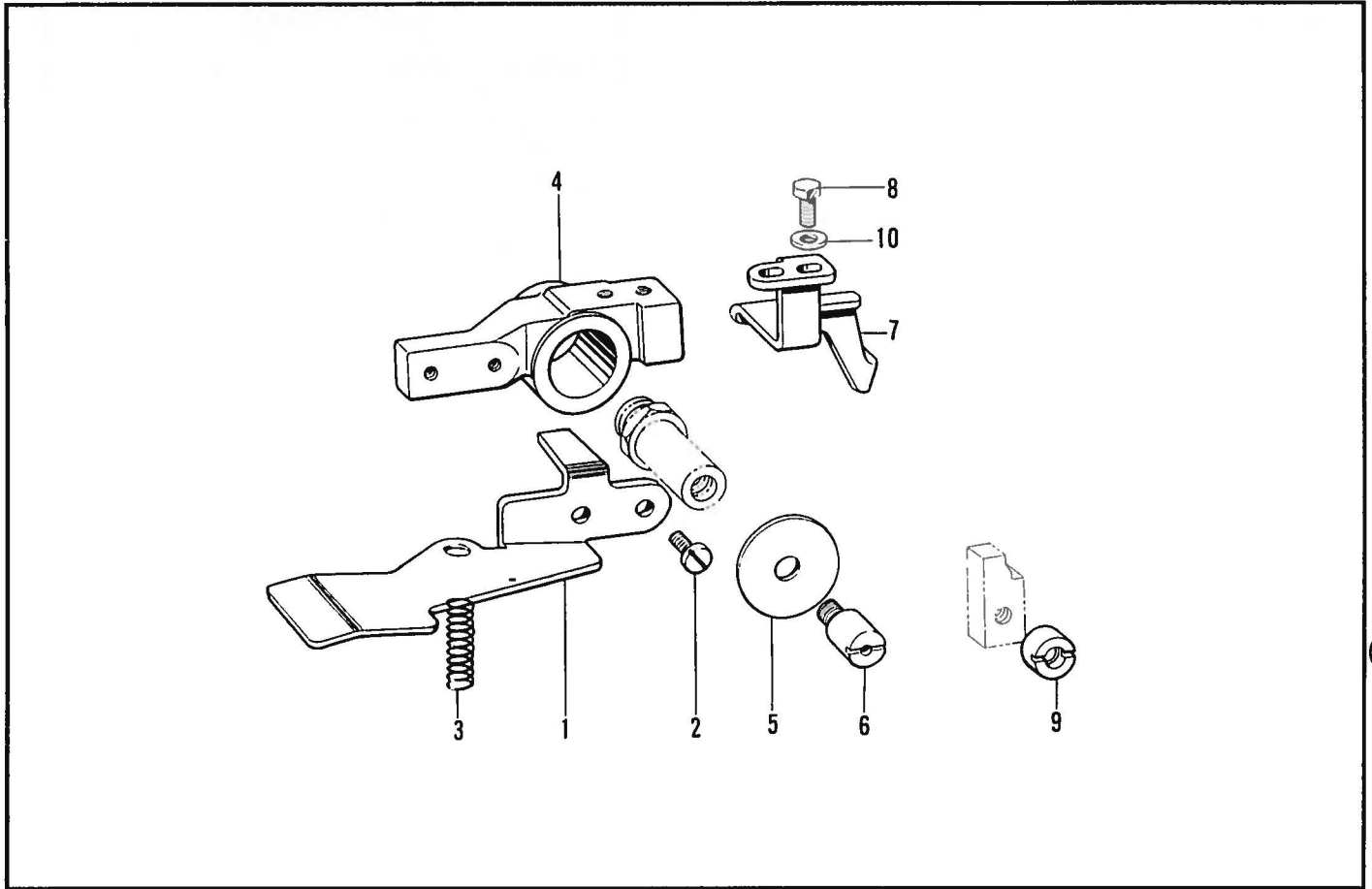

118-817-114

J. テンションプーリ関係/Tension pulley mechanism/Spannrolle/
Mécánisme de la poulie de tension/Mecanismo de la polea de tensión

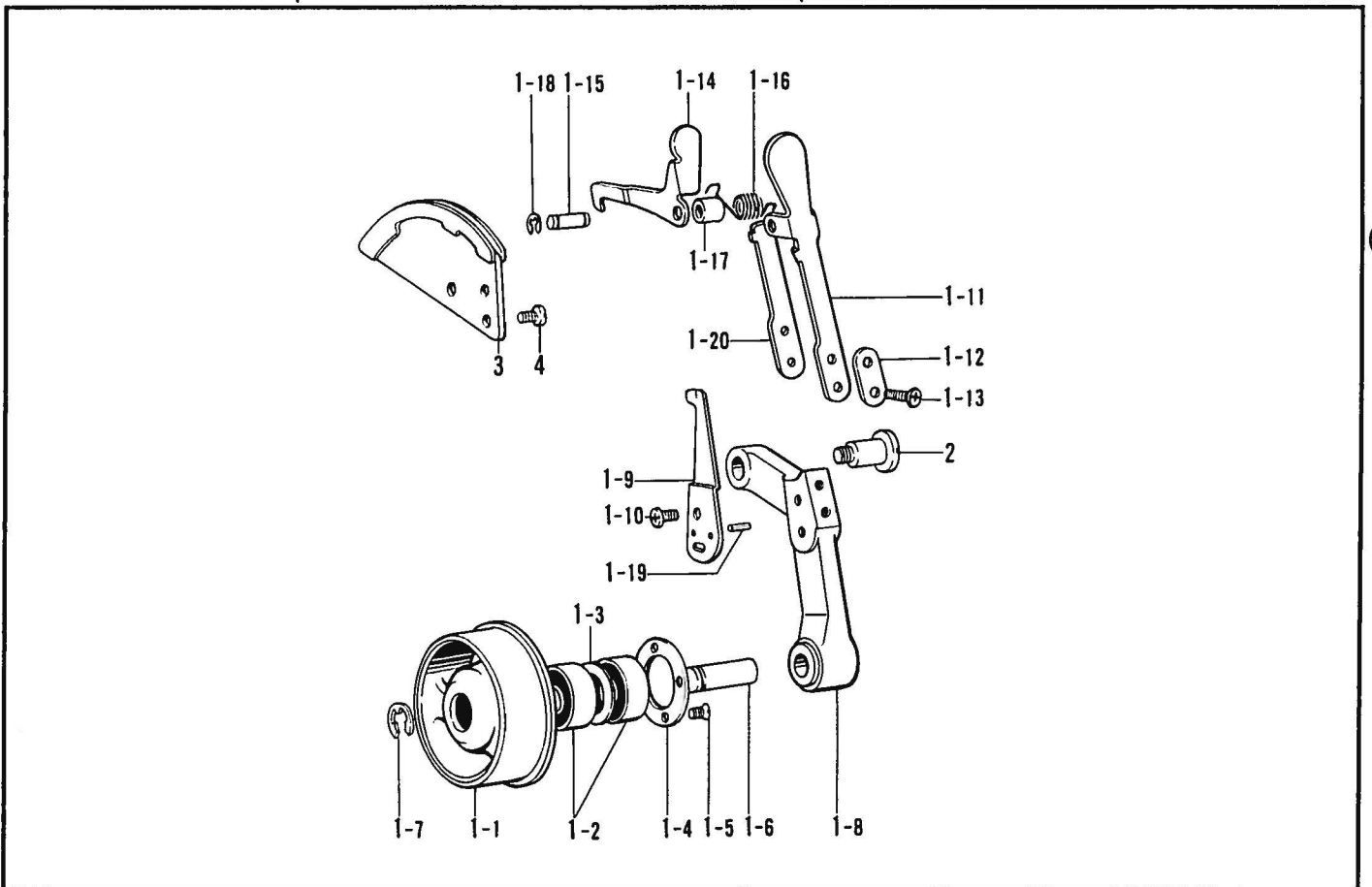

118-817-126

H. 非常停止関係/Emergency stop mechanism/Abschaltvorrichtung/

Mécanisme de l'arrêt de secours/Mecanismo de parada de emergencia

REF.NO.	CODE	Q'TY	ヒンメイ	NAME OF PARTS	RM
1	141698001	1	ヒジヨウテイシレバー	EMERGENCY STOP LEVER	
2	107407003	2	シメネジ4.37	SCREW 4.37	
3	141699001	1	テイシレバーオシバネ	SPRING, COMPRESSION	
4	141700001	1	ヒジヨウテイシテコ	EMERGENCY STOP LEVER	
5	141701001	1	ザガネ	WASHER	
6	141702001	1	テイシテコオサエネジ	STOP LEVER PRESSER SCREW	
7	141703001	1	ヒジヨウテイシコロホジイタ	HOLDING PLATE	
8	017681012	2	ボルト4.37X10	BOLT, M4.37X10	
9	141704001	1	ヒジヨウテイシセツシ	EMERGENCY STOP JOINT	
10	025680232	2	ヒラザガネチユウ4.37	WASHER, PLAIN M 4.37	

118-817-114

J. テンションプーリ関係/Tension pulley mechanism/Spannrolle/

Mécanisme de la poulie de tension/Mecanismo de la polea de tensión

REF.NO.	CODE	Q'TY	ヒンメイ	NAME OF PARTS	RM
1	141621001	1	テンションプーリクミ	TENSION PULLEY ASSY	
1-1	141622000	1	テンションプーリ	TENSION PULLEY	
1-2	072600040	2	タマジクウケ6000DD	BALL BEARING 6000DD	
1-3	142342000	1	カラー	WASHER	
1-4	141316001	1	ザガネ	WASHER	
1-5	110185002	4	サラネジ3.18	SCREW, FLAT M3.18	
1-6	141623001	1	テンションプーリジク	TENSION PULLEY SHAFT	
1-7	048090342	1	トメワE9	RETAINING RING, E9	
1-8	141624001	1	テンションプーリウデ	TENSION PULLEY ARM	
1-9	141625001	1	テンションシヒヨウイタ	TENSION PULLEY INDICATOR	
1-10	062670612	2	ナベコ357-40X6	SCREW, PAN M3.57-40X6	
1-11	143917001	1	テンションレバー	TENSION PULLEY LEVER	
1-12	141627001	1	テンションレバーザガネ	WASHER	
1-13	062671212	2	ナベコ357-40X12	SCREW, PAN M3.57-40X12	
1-14	141628001	1	テンションプーリツメ	TENSION PULLEY CLAW	
1-15	141629001	1	テンションプーリツメジク	TENSION PULLEY CLAW STUD	
1-16	141630001	1	テンションプーリツメバネ	SPRING	
1-17	141631001	1	カラー	COLLAR	
1-18	048030342	2	トメワE3	RETAINING RING, E3	
1-19	047250842	2	スプリングピンAW2.5	PIN, SPRING ROLL AW2.5	
1-20	143914001	1	テンションレバーS	TENSION LEVER (S)	
2	141632101	1	ダンネジ7.94	STUD SCREW 7.94	
3	141633001	1	ラチエツトクミ	TENSION PULLEY RATCHET ASSY	
4	062680812	3	ナベコ437-40X8	SCREW, PAN M4.37-40X8	

118-817-126

K. 押工関係/Presser foot mechanism/Stoffdrückerfuß/
 Mécanisme de pied presseur/Mecanismo de la prensa tela

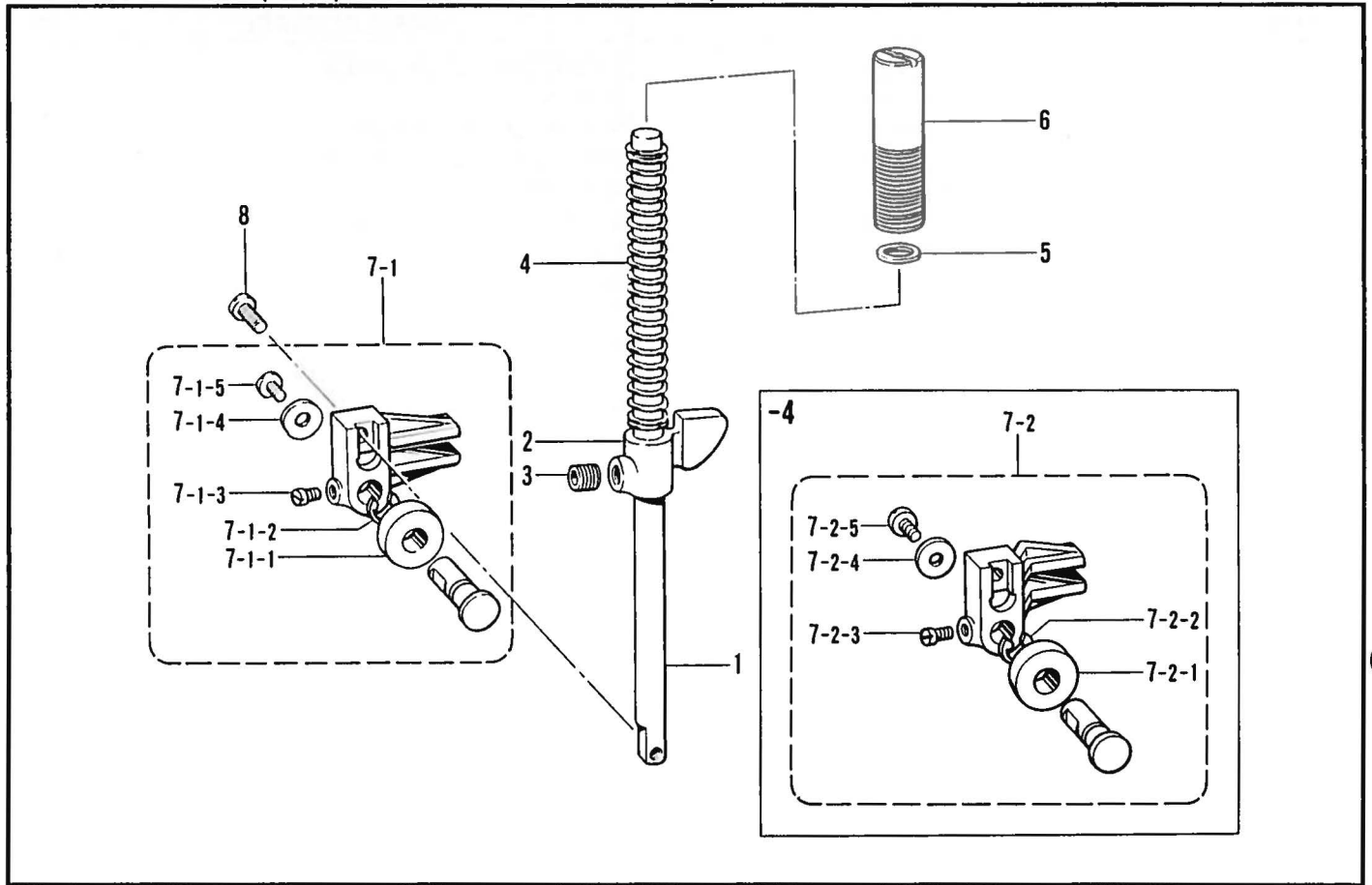

118-817-201

L. 糸切れ感知関係/Thread breakage detector mechanism/Fadenbruchfühler/
 Mécanisme du détecteur de cassure du fil/Mecanismo del sensor de cortes en el hilo

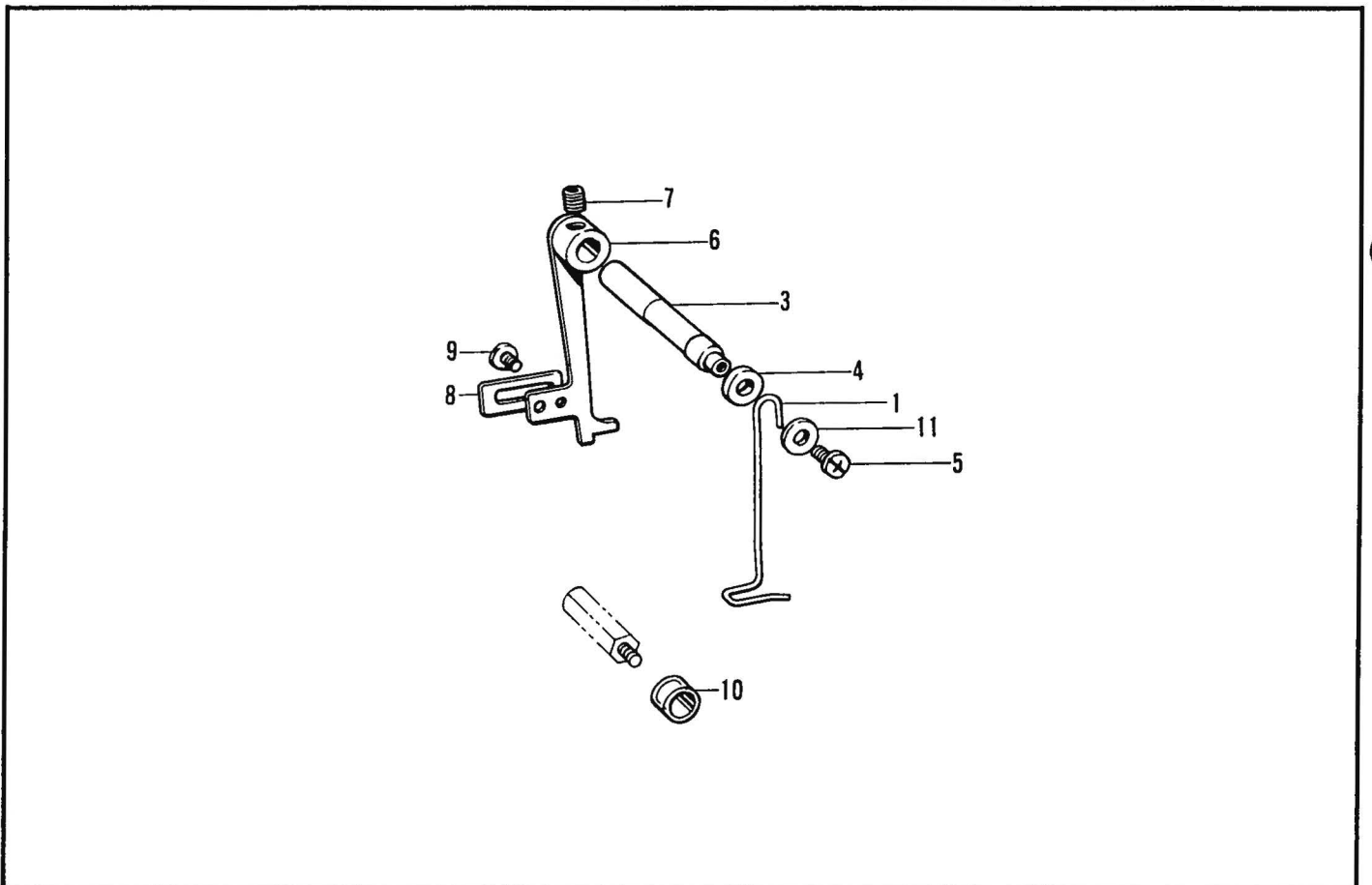

118-817-219

K. 押工関係/Presser foot mechanism/Stoffdrückerfuß/
Mécanisme de pied presseur/Mecanismo de la prensa tela

REF.NO.	CODE	Q'TY	ヒンメイ	NAME OF PARTS	RM
1	141449001	1	オサエボウ	PRESSER BAR	
2	141450001	1	オサエボウダキ	PRESSER BAR CLAMP	
3	014770622	1	アナトメネジ6.35クボミ	SET SCREW, SOCKET (CP) M6.35	
4	141451001	1	オサエバネL	SPRING (L)	
5	100281001	1	ザガネ	WASHER	
6	141454009	1	オサエチヨウセツネジ	ADJUST SCREW	
8	062681012	1	ナベコ437-40X10	SCREW, PAN M4.37-40X10	
			<-2,-3,-5>		
7-1	141455001	1	オサエローラクミ	PRESSER BAR ROLLER ASSY	
7-1-1	156879001	1	ローラ7X17	ROLLER 7X17	
7-1-2	048060342	1	トメワE6	RETAINING RING, E6	
7-1-3	100366002	1	マルヒラトメネジ4.37X5	SET SCREW 4.37X5	
7-1-4	025350332	1	ヒラザガネダイ3.5	WASHER, PLAIN L 3.5	
7-1-5	060670512	1	バインド357-40X5	SCREW, BIND M3.57-40X5	
			<-4>		
7-2	145377001	1	オサエローラクミ	PRESSER BAR ROLLER ASSY	
7-2-1	156880001	1	ローラ7X14	ROLLER 7X14	
7-2-2	048060342	1	トメワE6	RETAINING RING, E6	
7-2-3	100366002	1	マルヒラトメネジ4.37X5	SET SCREW 4.37X5	
7-2-4	025350332	1	ヒラザガネダイ3.5	WASHER, PLAIN L 3.5	
7-2-5	060670512	1	バインド357-40X5	SCREW, BIND M3.57-40X5	

118-817-201

L. 糸切れ感知関係/Thread breakage detector mechanism/Fadenbruchfühler/
Mécanisme du détecteur de cassure du fil/Mecanismo del sensor de cortes en el hilo

REF.NO.	CODE	Q'TY	ヒンメイ	NAME OF PARTS	RM
1	141614001	1	イトキレカンチセツシ	THREAD BREAKAGE PERCEIVING WIRE	
3	141616001	1	イトキレカンチレバージク	THREAD BREAKAGE PERCEIVING WIRE BAR	
4	141617001	1	カンチレバージクカラー	COLLAR	
5	060670612	1	バインド357-40X6	SCREW, BIND M3.57-40X6	
6	141619001	1	カツタオチボウシイタ	CUTTER BAR FIXED PLATE	
7	013760612	1	トメネジ5.95クボミ	SET SCREW, (CP) M5.95	
8	141620001	1	ボウシイタバランス	BALANCE	
9	101671002	1	シメネジ4.37	SCREW 4.37	
10	146253000	1	チューブ (L=5)	OIL TUBE (L=5)	
11	025350332	1	ヒラザガネダイ3.5	WASHER, PLAIN L 3.5	

118-817-219

M1. 送り関係/Feed mechanism/Transportvorrichtung/
 Mécanisme de l'entraînement/Mecanismo de la alimentación

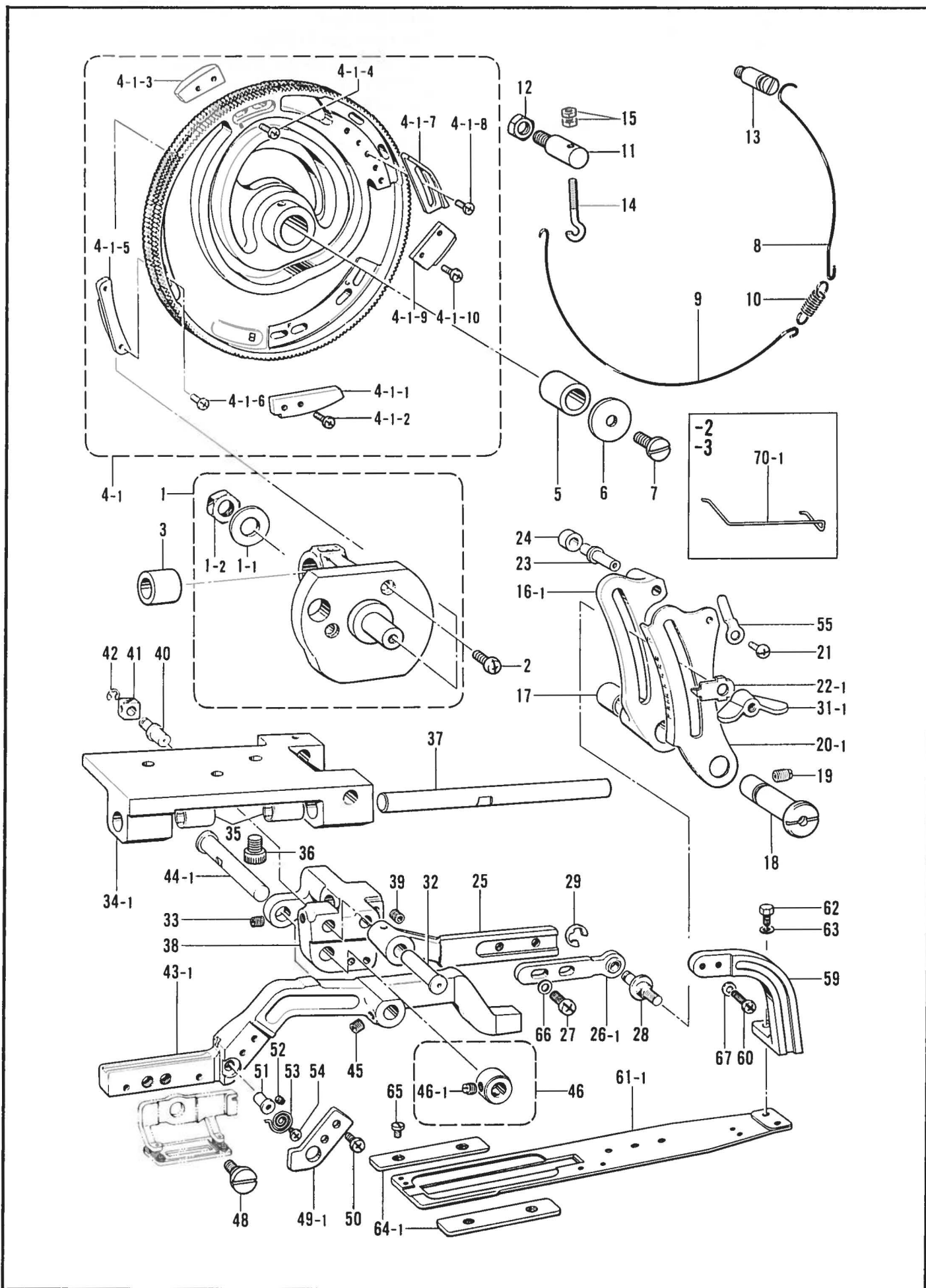

M1. 送り関係/Feed mechanism/Transportvorrichtung/
Mécanisme de l'entraînement/Mecanismo de la alimentación

REF.NO.	CODE	Q'TY	ヒンメイ	NAME OF PARTS	RM
1	141401001	1	オクリカムジククミ	FEED CAM SHAFT ASSY	
1-1	025900232	1	ヒラザガネチユウ12.70	WASHER, PLAIN M 12.70	
1-2	021910302	1	ナツト3シユ12.70	NUT, 3 M12.70	
2	062761212	3	ナベコ595-28X12	SCREW, PAN M5.95-28X12	
3	141404000	1	カムジクドダイメタル	FEED CAM SHAFT BRACKET BUSH	
5	142375000	1	オクリカムブシユ	FEED CAM BUSH	
6	141400009	1	ザガネ	WASHER	
7	141408009	1	シメネジヒダリ5.95	SCREW 5.95 (LEFT)	
8	141409001	1	カムブレーキハリカネA	CAM BRAKE WIRE (A)	
9	141410001	1	カムブレーキハリカネB	CAM BRAKE WIRE (B)	
10	141411001	1	カムブレーキヒキバネ	SPRING, EXTENSION	
11	141412001	1	カムブレーキハリカネカケA	CAM BRAKE WIRE HOOK (A)	
12	106147002	1	ナツト7.94	NUT 7.94	
13	141413001	1	カムブレーキハリカネカケB	CAM BRAKE WIRE HOOK (B)	
14	140947002	1	ウワイタチヨウセツネジ	ADJUST SCREW	
15	021400102	2	ナツト1シユ4	NUT, 1 M4	
17	142372000	2	DUブシユ	(DU) BUSH	
18	141417009	1	オクリチヨウセツレバージク	LENGTH FEED ADJUST LEVER SHAFT	
19	151605002	1	トメネジ5.95	SET SCREW, M5.95	
21	062670612	1	ナベコ357-40X6	SCREW, PAN M3.57-40X6	
23	141420001	1	オクリコロジク	ROLLER SHAFT	
24	107550002	1	コロ	ROLLER	
25	141421009	1	オクリレバーA	FEED LEVER (A)	
27	062761012	2	ナベコ595-28X10	SCREW, PAN M5.95-28X10	
28	147945001	1	オクリレバーBジク	FEED LEVER (B) JOINT	
29	048050342	1	トメワE5	RETAINING RING, E5	
32	141426001	1	オクリレバーAジク	FEED LEVER (A) STUD	
33	014770622	1	アナトメネジ6.35クボミ	SET SCREW, SOCKET (CP) M6.35	
35	142374000	2	DUブシユ	(DU) BUSH	
36	018081422	3	アナボルト8X14	BOLT, SOCKET M8X14	
37	141429001	1	オクリアンナイジク	FEED GUIDE SHAFT	
38	141430009	1	オクリウデシテン	FEED ARM BRACKET	
39	014770622	1	アナトメネジ6.35クボミ	SET SCREW, SOCKET (CP) M6.35	
40	141431001	1	オクリウデシテンジク	FEED ARM FULCRUM SHAFT	
41	118215001	1	オクリダイカクコマ	FEED BAR SLIDE BLOCK	
42	048040342	1	トメワE4	RETAINING RING, E4	
45	014770622	1	アナトメネジ6.35クボミ	SET SCREW, SOCKET (CP) M6.35	
46	181969003	1	セツトカラークミ	SET COLLAR ASSY	
46-1	101706003	2	トメネジ6.35	SET SCREW, M6.35	
48	141439001	1	ダンネジ6.35	STUD SCREW 6.35	
50	062680612	2	ナベコ4.37-40X6	SCREW, PAN M4.37-40X6	
51	141441001	1	ヌノツカミササエバネジク	SPRING SHAFT	
52	151601002	1	トメネジ4.37	SET SCREW, M4.37	
53	141442001	1	ヌノツカミササエバネ	SPRING	
54	062660412	1	ナベコ318-40X4	SCREW, PAN M3.18-40X4	
66	118735002	2	ザガネ	WASHER	

M1 . 送り関係/Feed mechanism/Transportvorrichtung/
 Mécanisme de l'entraînement/Mecanismo de la alimentación

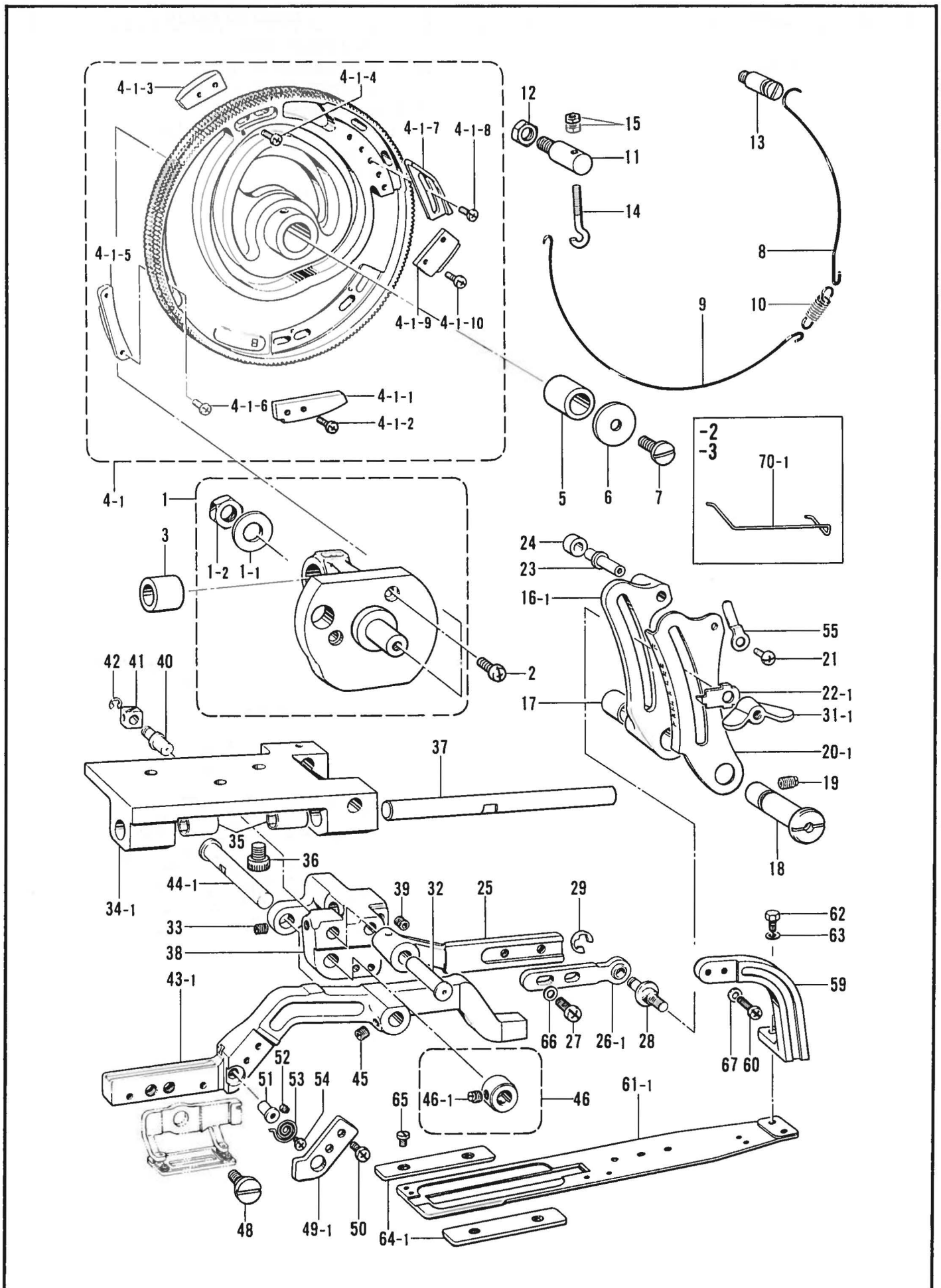

M1. 送り関係/Feed mechanism/Transportvorrichtung/
Mécanisme de l'entraînement/Mecanismo de la alimentación

REF.NO.	CODE	Q'TY	ヒンメイ	NAME OF PARTS	RM
			<-2,-3,-5>		
4-1	143942101	1	オクリカムクミ	FEED CAM ASSY	
4-1-1	143943001	1	イトユルメカムヘンF	TENSION RELEASE CAM SEGMENT (F)	
4-1-2	062681012	2	ナベコ437-40X10	SCREW, PAN M4.37-40X10	
4-1-3	143944001	1	イトユルメカムヘンB	TENSION RELEASE CAM SEGMENT (B)	
4-1-4	062681212	2	ナベコ437-40X12	SCREW, PAN M4.37-40X12	
4-1-5	141445001	2	カントメカムヘン	BAR TACK CAM SEGMENT	
4-1-6	062681212	4	ナベコ437-40X12	SCREW, PAN M4.37-40X12	
4-1-7	141446001	1	テイシカムヘンA	STOP CAM SEGMENT (A)	
4-1-8	062681012	2	ナベコ437-40X10	SCREW, PAN M4.37-40X10	
4-1-9	141448001	1	カツタカムヘン	CUTTER CAM SEGMENT	
4-1-10	062681012	2	ナベコ437-40X10	SCREW, PAN M4.37-40X10	
44-1	141434001	1	オクリウデジク	FEED ARM SHAFT	
			<-2,-3>		
20-1	143740001	1	オクリメモリタ	STITCH LENGTH CONTROL PLATE	
26-1	141422001	1	オクリレバーBクミ	FEED LEVER (B) ASSY	
34-1	141427009	1	オクリアンナイジクドダイ	FEED GUIDE SHAFT BRACKET	
43-1	141433009	1	ナガサオクリウデ	LENGTH FEED ARM	
64-1	143743001	2	ナガサオクリイタアンナイ	LENGTH FEED GUIDE PLATE	
70-1	150562000	1	-----	FINGER GUARD (M)	
			<-2,-3,-4>		
16-1	143739009	1	オクリチヨウセツレバー	LENGTH FEED ADJUST LEVER	
22-1	141419001	1	メモリシジイタ	LENGTH FEED INDICATOR	
31-1	118262002	1	チヨウセツナツト5.95	NUT 5.95	
49-1	141440001	1	ヌノツカミササエアンナイ	GUIDE PLATE	
55	144541001	1	メモリイタストツバ	LENGTH CONTROL PLATE STOPPER	
59	143738009	1	シタオクリウデ	LOWER FEED ARM	
60	062682012	2	ナベコ437-40X20	SCREW, PAN M4.37-40X20	
62	017681012	2	ボルト4.37X10	BOLT, M4.37X10	
63	100645003	2	ザガネ	WASHER	
65	106568003	4	シメネジ3.57	SCREW 3.57	
67	100645003	2	ザガネ	WASHER	
			<-2>		
61-1	145248001	1	ナガサオクリイタ	LENGTH FEED PLATE	

M2. 送り関係/Feed mechanism/Transportvorrichtung/
 Mécanisme de l'entraînement/Mecanismo de la alimentación

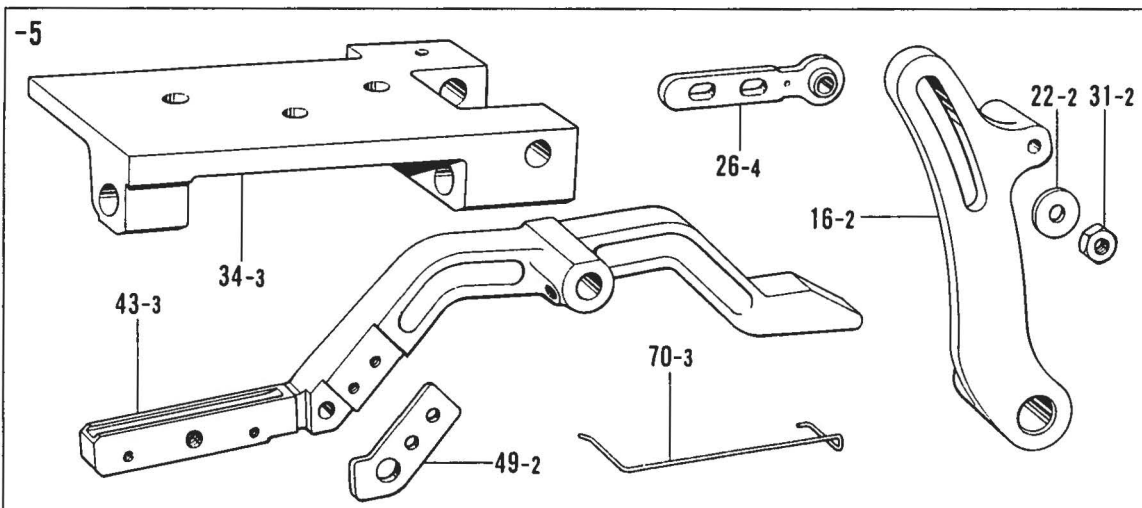
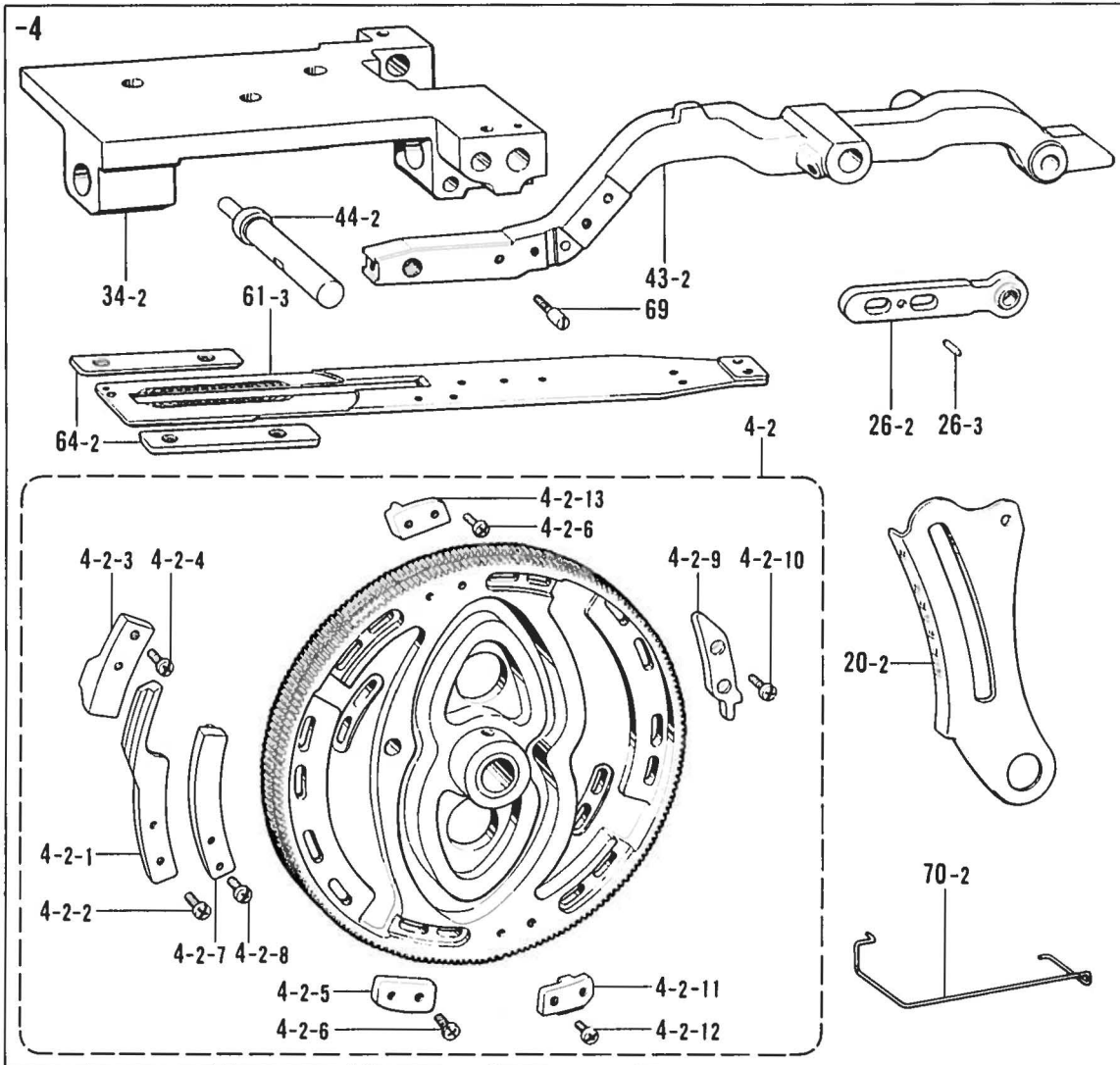
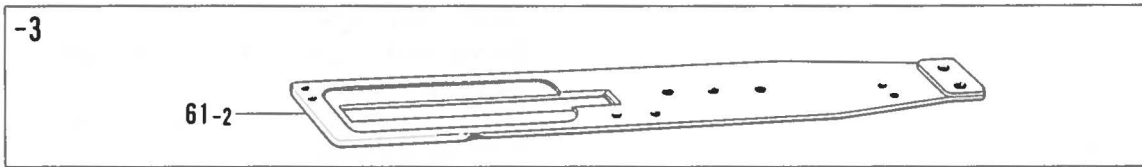

M2 . 送り関係/Feed mechanism/Transportvorrichtung/
Mécanisme de l'entraînement/Mecanismo de la alimentación

REF.NO.	CODE	Q'TY	ヒンメイ	NAME OF PARTS	RM
61-2	144627001	1	<-3> ナガサオクリイタ	LENGTH FEED PLATE	
4-2	146336001	1	<-4> オクリカムクミ	FEED CAM ASSY	
4-2-1	145348001	2	オシカム	PUSH CAM	
4-2-2	062681212	4	ナベコ437-40X12	SCREW, PAN M4.37-40X12	
4-2-3	146338001	2	フリカムB	ZIGZAG CAM SEGMENT (B)	
4-2-4	062681212	4	ナベコ437-40X12	SCREW, PAN M4.37-40X12	
4-2-5	145350001	1	フリカムF	ZIGZAG CAM SEGMENT (F)	
4-2-6	062681012	4	ナベコ437-40X10	SCREW, PAN M4.37-40X10	
4-2-7	145351001	2	カントメカム	BAR TACK CAM SEGMENT	
4-2-8	062680812	4	ナベコ437-40X8	SCREW, PAN M4.37-40X8	
4-2-9	145352001	1	テイシカム	STOP CAM SEGMENT	
4-2-10	062680812	2	ナベコ437-40X8	SCREW, PAN M4.37-40X8	
4-2-11	145353001	1	カツターカム	CUTTER CAM SEGMENT	
4-2-12	062681012	2	ナベコ437-40X10	SCREW, PAN M4.37-40X10	
4-2-13	146130001	1	フリカムFB	ZIGZAG CAM SEGMENT (FB)	
20-2	145359001	1	オクリメモリイタ	STITCH LENGTH CONTROL PLATE	
26-2	145445001	1	オクリレバーBクミ	FEED LEVER (B) ASSY	
26-3	047400842	1	スプリングピンAW4X8	PIN, SPRING ROLL AW4X8	
34-2	145354009	1	オクリアンナイジクドダイ	FEED GUIDE SHAFT BRACKET	
43-2	145356009	1	ナガサオクリウデ	LENGTH FEED ARM	
44-2	145355001	1	オクリウデジク	FEED ARM SHAFT	
61-3	145357001	1	ナガサオクリイタ	LENGTH FEED PLATE	
64-2	145358001	2	ナガサオクリイタアンナイ	LENGTH FEED PLATE GUIDE	
69	115120001	1	ハリカズヘンカンギャピン	PIN	
70-2	150566000	1	-----	FINGER GUARD (M)	
16-2	147229009	1	<-5> オクリチヨウセツレバー	LENGTH FEED ADJUST LEVER	
22-2	025060332	1	ヒラザガネダイ6	WASHER, PLAIN L 6	
26-4	147939001	1	オクリレバーBクミ	FEED LEVER (B) ASSY	
31-2	106588003	1	ナツト5.95	NUT 5.95	
34-3	151583009	1	オクリアンナイジクドダイ	FEED GUIDE SHAFT BRACKET	
43-3	147228009	1	ナガサオクリウデ	LENGTH FEED ARM	
49-2	147232001	1	ヌノツカミササエアンナイ	GUIDE PLATE	
70-3	150564000	1	-----	FINGER GUARD (LL)	

M3 . 送り関係/Feed mechanism/Transportvorrichtung/
 Mécanisme de l'entraînement/Mecanismo de la alimentación

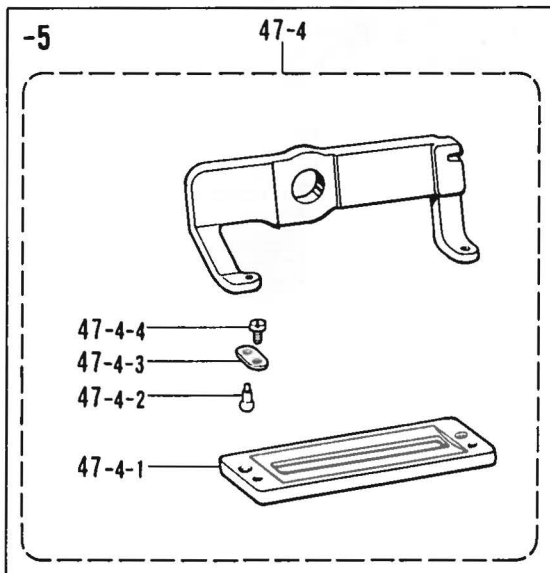
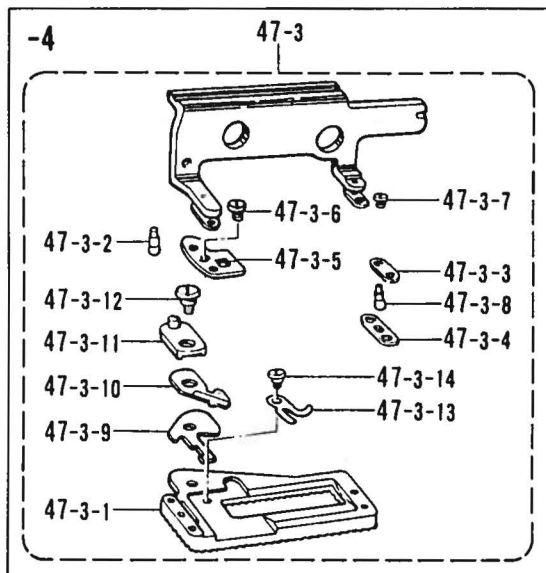
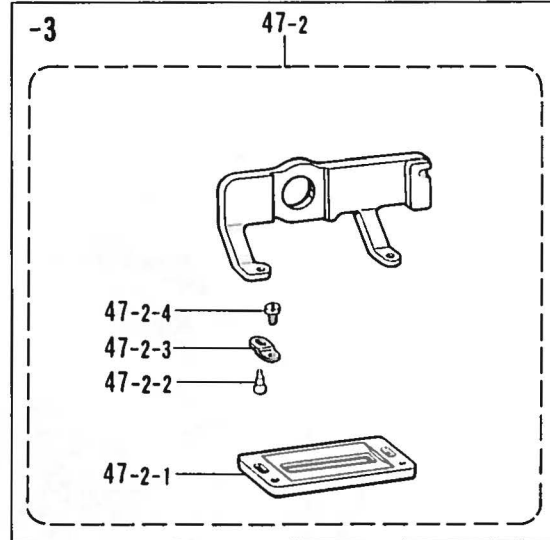
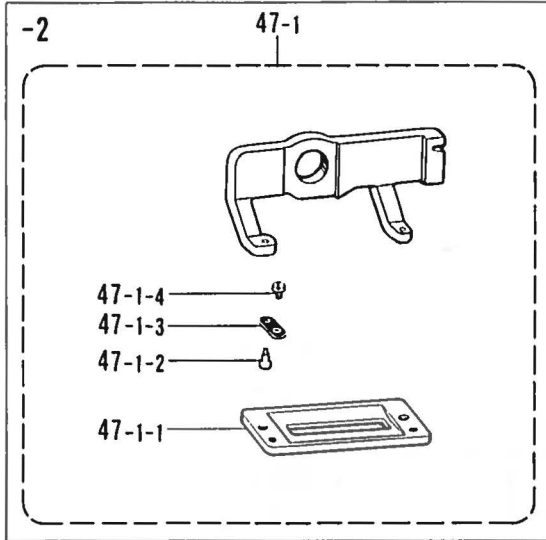

M3 . 送り関係/Feed mechanism/Transportvorrichtung/
Mécanisme de l'entraînement/Mecanismo de la alimentación

REF.NO.	CODE	Q'TY	ヒンメイ	NAME OF PARTS	RM
			<フィンガーガード用>	<For finger guard>	
			<-2>		
47-1	150764001	1	ヌノツカミ25クミ	UPPER CLAMPING FOOT ASSY (25MM)	
47-1-1	144498001	1	ヌノツカミゴム	UPPER CLAMPING FOOT RUBBER	
47-1-2	144496001	2	ヌノツカミササエピン	PIN	
47-1-3	107401001	2	ヌノツカミササエイタバネ	SPRING,PLATE	
47-1-4	107404001	2	シメネジ1.98	SCREW 1.98	
			<-3>		
47-2	150768001	1	ニットヨウヌノツカミ25クミ	UPPER CLAMPING FOOT ASSY (25MM-3)	
47-2-1	144630001	1	ニットヨウヌノツカミ	UPPER CLAMPING FOOT	
47-2-2	144496001	2	ヌノツカミササエピン	PIN	
47-2-3	144707001	2	ヌノツカミササエイタバネ	SPRING,PLATE	
47-2-4	107404001	2	シメネジ1.98	SCREW 1.98	
			<-4>		
47-3	150770001	1	ヌノツカミ(25-4)クミ	UPPER CLAMPING FOOT ASSY (25MM-4)	
47-3-1	145362001	1	ヌノツカミ(25-4)	UPPER CLAMPING FOOT (25MM-4)	
47-3-2	144496001	1	ヌノツカミササエピン	PIN	
47-3-3	107401001	1	ヌノツカミササエイタバネ	SPRING,PLATE	
47-3-4	145365001	1	ヌノツカミイタバネ	SPRING,PLATE	
47-3-5	145366001	1	イトオサエ	THREAD PRESSER	
47-3-6	111105001	2	シメネジ2.38	SCREW 2.38	
47-3-7	107404001	1	シメネジ1.98	SCREW 1.98	
47-3-8	146034001	1	ヌノツカミササエピン	PIN	
47-3-9	145367001	1	ヒモキリコティバ	GIMP TRIMMING FIXED KNIFE	
47-3-10	145731001	1	ヒモキリイドウハクミ	GIMP TRIMMING MOVABLE KNIFE ASSY	
47-3-11	145369001	1	ヒモキリクランク	GIMP TRIMMING CRANK	
47-3-12	145370001	1	ダンネジ3.57	STUD SCREW 3.57	
47-3-13	145373001	1	ヒモヨセレバー	GIMP DETACH LEVER	
47-3-14	145371001	1	ダンネジ2.38	STUD SCREW 2.38	
			<-5>		
47-4	150766001	1	ヌノツカミ50クミ	UPPER CLAMPING FOOT ASSY (50MM)	
47-4-1	147230001	1	ヌノツカミ50	UPPER CLAMPING FOOT (50MM)	
47-4-2	144496001	2	ヌノツカミササエピン	PIN	
47-4-3	107401001	2	ヌノツカミササエイタバネ	SPRING,PLATE	
47-4-4	107404001	2	シメネジ1.98	SCREW 1.98	

N. カム伝導関係/Feed cam mechanism/Transporteurkurve/
Mécanisme de la came déentraînement/Mecanismo de la leva de alimentación

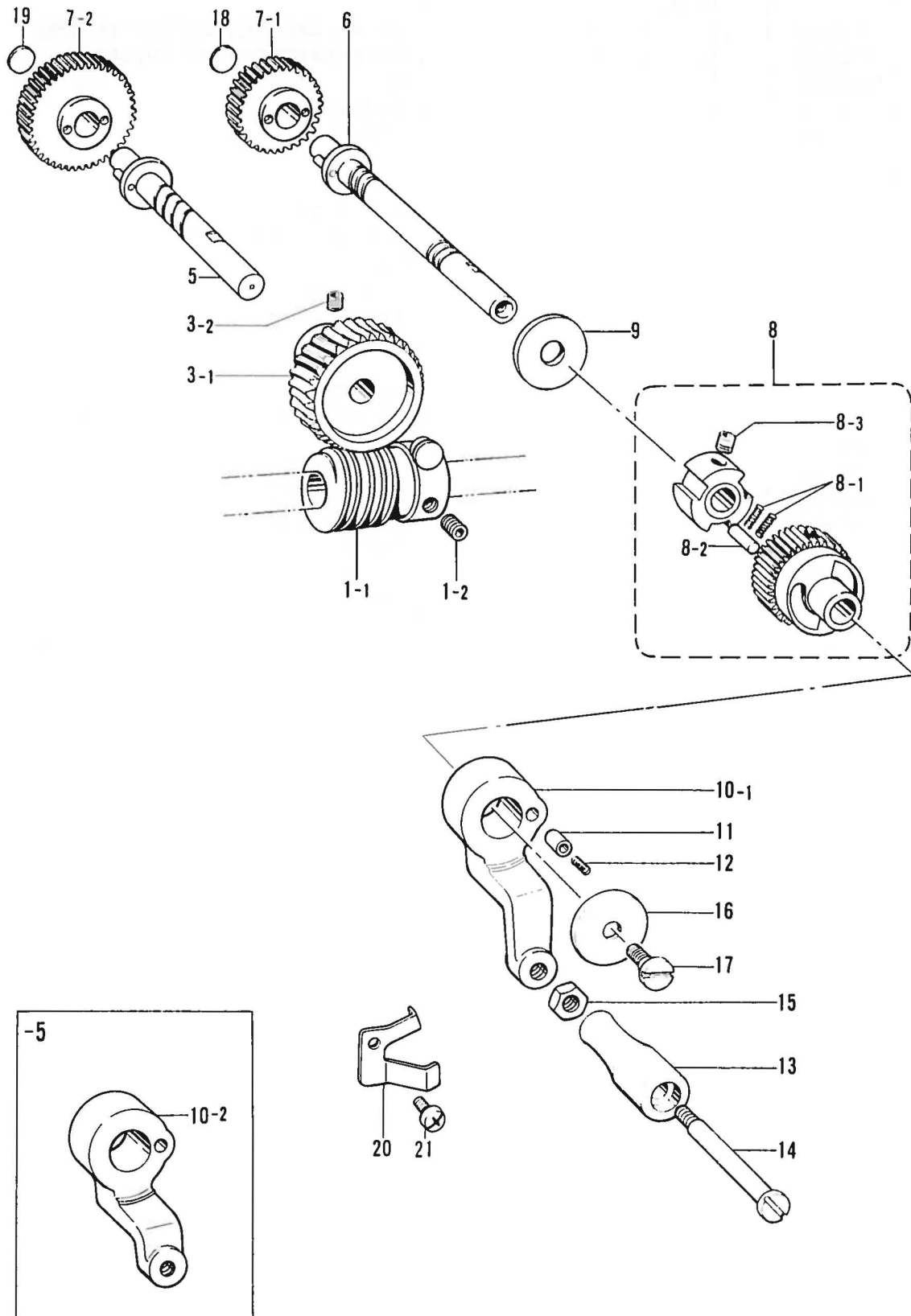

N. カム伝導関係/Feed cam mechanism/Transporteurkurve/
Mécanisme de la came déentraînement/Mecanismo de la leva de alimentación

REF.NO.	CODE	Q'TY	ヒンメイ	NAME OF PARTS	RM
1	183704001	1	ウオームクミ	WORM ASSY	
1-1	141367001	1	ウオーム	WORM	
1-2	014770622	2	アナトメネジ6.35クボミ	SET SCREW, SOCKET (CP) M6.35	
3	183705001	1	ウオームギヤクミ	WORM GEAR ASSY	
3-1	141368000	1	ウオームギヤ	WORM GEAR	
3-2	014770622	2	アナトメネジ6.35クボミ	SET SCREW, SOCKET (CP) M6.35	
5	141369101	1	ウオームギヤジククミ	WORM GEAR SHAFT ASSY	
6	141714001	1	チェンジギヤジククミ	CHANGE GEAR SHAFT ASSY	
8	141389001	1	フリーホイールクミ	FREE WHEEL CAM ASSY	
8-1	141392001	6	フリーホイールカムオシバネ	SPRING, COMPRESSION	
8-2	141393001	3	ニードルコロ	NEEDLE ROLLER	
8-3	014760622	2	アナトメネジ5.95	SET SCREW, SOCKET (CP) M5.95	
9	141394001	1	ザガネ	WASHER	
11	141396001	1	クラッチピン	CLUTCH PIN	
12	141397001	1	クラッチオシバネ	SPRING, COMPRESSION	
13	141398009	1	ハンドル	HANDLE	
14	141399001	1	ハンドルジク	HANDLE SHAFT	
15	150556001	1	ナツト6.35	NUT 6.35	
16	141400009	1	ザガネ	WASHER	
17	142702001	1	ダンネジ5.56	STUD SCREW 5.56	
18	142272001	1	チェンジギヤモジイタR	GEAR INDICATOR (R)	
19	142273001	1	チェンジギヤモジイタL	GEAR INDICATOR (L)	
20	147317001	1	ハンドルレバーオサエバネ	SPRING, PLATE	
21	062680512	1	ナベコ437-40X5	SCREW, PAN M4.37-40X5	
10-1	S32997009	1	<-2,-3,-4> ハンドルレバー	HANDLE LEVER	
10-2	S32998009	1	<-5> ハンドルレバー5	HANDLE LEVER 5	
7-1	141378000	1	<-2,-4> チェンジギヤ34	CHANGE GEAR 34	
7-2	141382000	1	チェンジギヤ42	CHANGE GEAR 42	
7-1	141374000	1	<-3> チェンジギヤ26	CHANGE GEAR 26	
7-2	141386000	1	チェンジギヤ50	CHANGE GEAR 50	
7-1	141377000	1	<-5> チェンジギヤ32	CHANGE GEAR 32	
7-2	141383000	1	チェンジギヤ44	CHANGE GEAR 44	

P. カッター関係/Cutter mechanism/Abschneidevorrichtung/
 Mécanisme de la coupe/Mecanismo de la corta

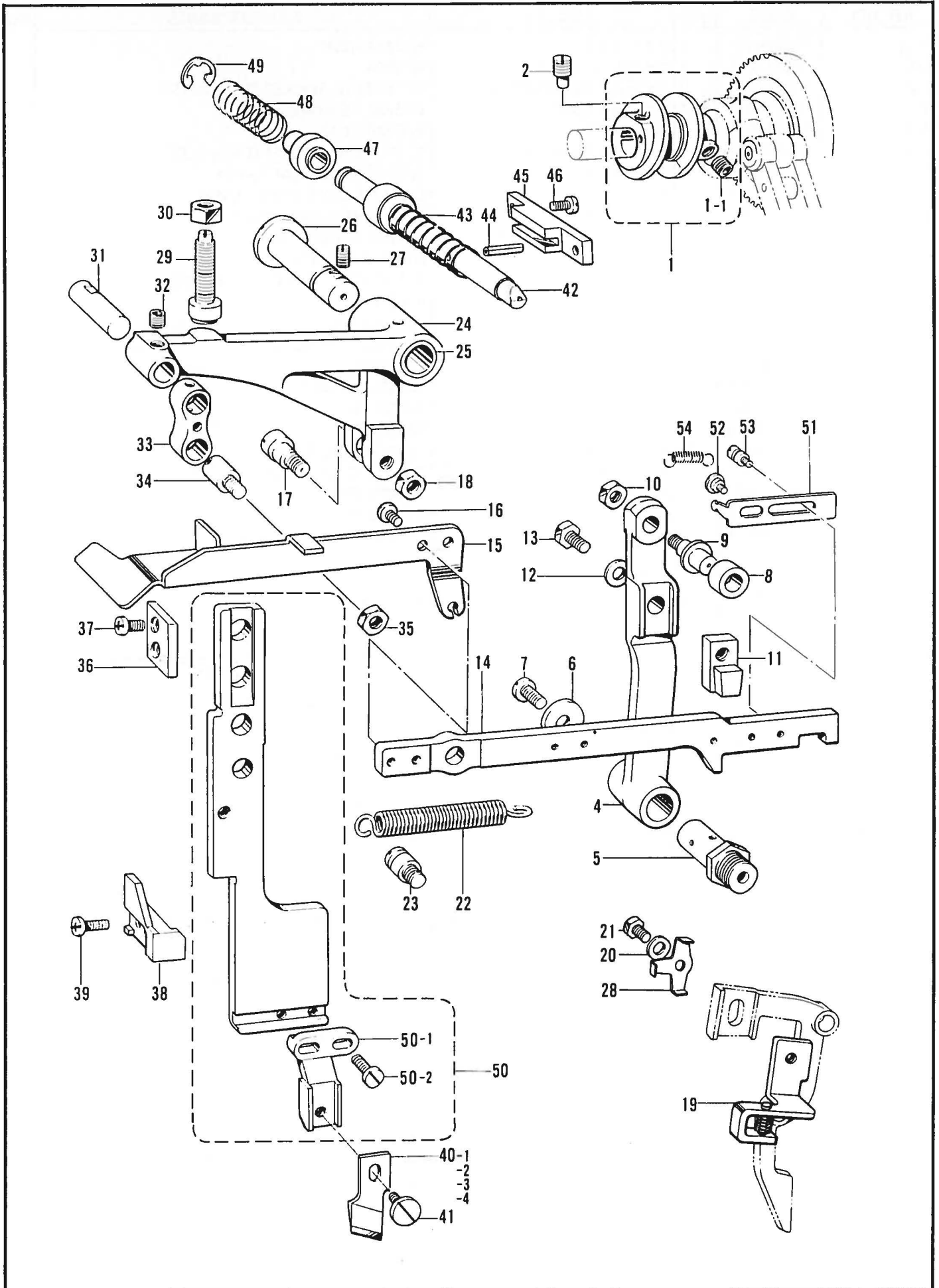

P. カッター関係/Cutter mechanism/Abschneidevorrichtung/
Mécanisme de la coupe/Mecanismo de la corta

REF.NO.	CODE	Q'TY	ヒンメイ	NAME OF PARTS	RM
1	181250001	1	カッターカムネジツキ	CUTTER CAM WITH SCREW	
1-1	014770622	1	アナトメネジ6.35クボミ	SET SCREW, SOCKET (CP) M6.35	
2	141717001	1	カッタカムセットネジ	CUTTER CAM SET SCREW	
4	141462001	1	カッタサドウレバー	CUTTER CONNECTING LEVER	
5	141463001	1	カッタサドウレバージク	LEVER SHAFT	
6	149095001	1	ザガネ	WASHER	
7	062761212	1	ナベコ595-28X12	SCREW, PAN M5.95-28X12	
8	141464101	1	カッタサドウコロ	ROLLER	
9	141465001	1	カッタサドウコロジク	ROLLER SHAFT	
10	106588003	1	ナツト5.95	NUT 5.95	
11	141466001	1	カッタサドウカクコマ	CUTTER CONNECTING SLIDE BLOCK	
12	109893002	1	ザガネ	WASHER	
13	017772012	1	ボルト6.35X20	BOLT, M6.35X20	
14	141467001	1	カッタレバー	CUTTER LEVER	
15	532999001	1	カッタオチボウシレバー	CUTTER STOP LEVER	
16	062680812	2	ナベコ437-40X8	SCREW, PAN M4.37-40X8	
17	141469001	1	ヘンシンダンネジ	STUD SCREW	
18	110744002	1	ナツト6.35	NUT 6.35	
19	143945001	1	カッターレバーササエイタクミ	CUTTER LEVER SUPPORT PLATE ASSY	
20	107453001	1	ザガネ	WASHER	
21	017751412	1	ボルト5.56X14	BOLT, M5.56X14	
22	141471001	1	カッタレバーヒキバネ	SPRING,EXTENSION	
23	141472002	1	シタイトキリレバーバネカケ	SPRING HOOK	
24	141473009	1	カッタテコ	CUTTER BASE LIFTER LEVER	
25	142376000	1	カッタテコブシユ	CUTTER LEVER BUSH	
26	141417009	1	オクリチヨウセツレバージク	LENGTH FEED ADJUST LEVER SHAFT	
27	014780622	1	アナトメネジ6.35クボミ	SET SCREW, SOCKET (CP) M6.35	
28	143927001	1	コティザガネ	WASHER	
29	141481001	1	カッタテコトメクミ	CUTTER BASE LIFTER STOPPER WITH RUBBER	
30	152998001	1	ナツト9.52	NUT 9.52	
31	141474001	1	カッタサドウリンクジクA	CUTTER DRIVING LINK STUD (A)	
32	014770622	1	アナトメネジ6.35クボミ	SET SCREW, SOCKET (CP) M6.35	
33	141475001	1	カッタサドウリンク	CUTTER BASE CONNECTING LINK	
34	141476001	1	カッタサドウリンクジクB	CUTTER DRIVING LINK STUD (B)	
35	150553003	1	ナツト5.95	NUT 5.95	
36	141478001	1	カッタドダイアンナイU	CUTTER BASE GUIDE (U)	
37	062680712	2	ナベコ437-40X7	SCREW, PAN M4.37-40X7	
38	141479001	1	カッタドダイアンナイD	CUTTER BASE GUIDE (D)	
39	062681412	2	ナベコ437-40X14	SCREW, PAN M4.37-40X14	
40-1	107200001	1	カッタ1/2 <-2>	CUTTER 1/2" <-2>	
40-2	107204001	1	カッタ7/16 <-3>	CUTTER 7/16" <-3>	
40-3	107205001	1	カッタ5/8 <-4>	CUTTER 5/8" <-4>	
40-4	147941001	1	カッタ48 <-5>	CUTTER 48" <-5>	
41	115503001	1	シメネジ4.37	SCREW 4.37	
42	141484001	1	カッタクラツチボウ	CUTTER CLUTCH BAR	
43	141485001	1	カッタクラツチオシバネA	SPRING,COMPRESSION (A)	
44	047301842	1	スプリングピンAW3	PIN, SPRING 3X18	
45	141486001	1	カッタクラツチボウアンナイ	CUTTER CLUTCH BAR GUIDE	
46	062670812	2	ナベコ3.57-40X8	SCREW, PAN M3.57-40X8	
47	141487001	1	カッタクラツチ	CUTTER CLUTCH	
48	141488001	1	カッタクラツチオシバネB	SPRING,COMPRESSION (B)	
49	048080342	1	トメワE8	RETAINING RING, E8	
50	142724001	1	カッタドダイクミ	CUTTER BRACKET ASSY	
50-1	141480001	1	カッタトリツケイタ	CUTTER HOLDER	
50-2	107407003	2	シメネジ4.37	SCREW 4.37	
51	142779001	1	カッタカクコマクラツチ	CUTTER SLIDE BLOCK CLUTCH	
52	112144001	2	ダンネジ3.57	STUD SCREW 3.57	
53	107126001	1	ティシレバーバネカケ	SPRING HOOK	
54	120790001	1	ヒキバネ	SPRING,EXTENSION	

Q. ヒモ案内関係/Gimp guide mechanism/Schnurführung/
Mécanisme de guide-fil/Mecanismo guía del hilo

-4

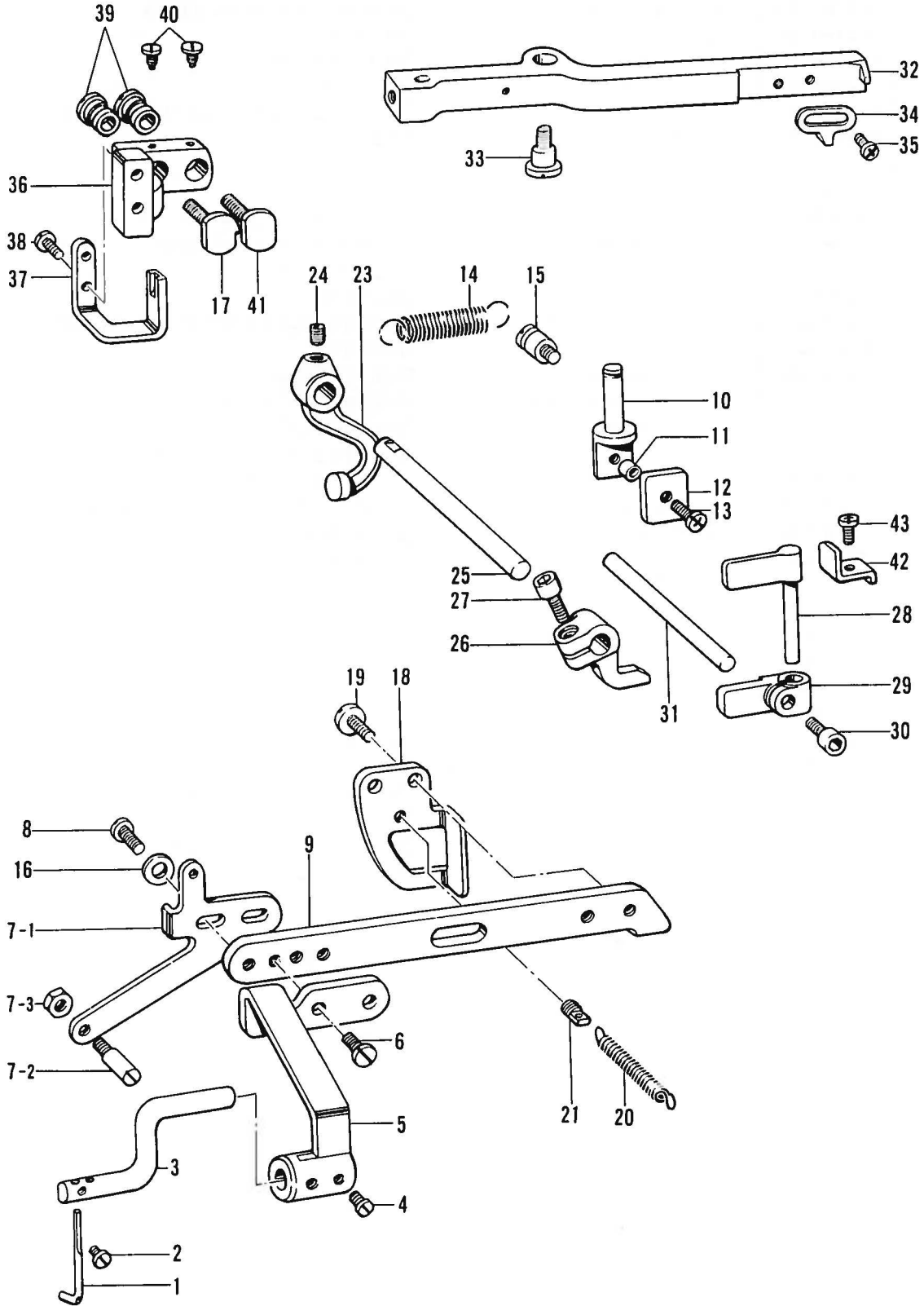

Q. ヒモ案内関係/Gimp guide mechanism/Schnurführung/
Mécanisme de guide-fil/Mecanismo guía del hilo

REF.NO.	CODE	Q'TY	ヒンメイ	NAME OF PARTS	RM
			<-4>		
1	145380001	1	ヒモアンナイ	GIMP GUIDE PIPE	
2	111443003	1	マルヒラトメネジ3.57	SET SCREW 3.57	
3	145381001	1	ヒモアンナイボウ	GIMP GUIDE BAR	
4	100366002	2	マルヒラトメネジ4.37X5	SET SCREW 4.37X5	
5	145382001	1	ヒモアンナイボウササエ	GIMP GUIDE BAR SUPPORT	
6	107407003	2	シメネジ4.37	SCREW 4.37	
7	145383101	1	ヒモアンナイキリカエイタクミ	GIMP GUIDE CHANGING PLATE ASSY	
7-1	147758001	1	ヒモアンナイキリカエイタ	GIMP GUIDE CHANGING PLATE	
7-2	141504001	1	イトキリレバーササエボウ	THREAD TRIMMING LEVER SUPPORT STUD	
7-3	110161004	1	ナツト4.76	NUT 4.76	
8	107407003	2	シメネジ4.37	SCREW 4.37	
9	145384001	1	ヒモアンナイレンカン	GIMP GUIDE CONNECTING ROD	
10	145385001	1	ヒモアンナイヒンヂ	GIMP GUIDE HINGE	
11	145386001	1	ヒンヂコロ	HINGE ROLLER	
12	145387001	1	ヒンヂザガネ	HINGE WASHER	
13	062711212	1	ナベコ476-32X12	SCREW, PAN M4.76-32X12	
14	145692001	1	ヒモアンナイモドシバネ	SPRING, EXTENSION	
15	145388001	1	バネカケ	SPRING HOOK	
16	025680232	2	ヒラザガネチユウ4.37	WASHER, PLAIN M 4.37	
17	146316001	1	イチチヨウセツネジL	ADJUST SCREW (L)	
18	145392001	1	ヒモアンナイオシイタ	GIMP GUIDE PUSHING PLATE	
19	107407003	2	シメネジ4.37	SCREW 4.37	
20	146951001	1	ヒモアンナイヨコバネ	SPRING, EXTENSION	
21	107640001	1	バネカケD	SPRING HOOK (D)	
23	145394001	1	ヒモアンナイオシレバーA	GIMP GUIDE PUSHING LEVER (A)	
24	014770622	1	アナトメネジ6.35クボミ	SET SCREW, SOCKET (CP) M6.35	
25	145395001	1	ヒモアンナイオシレバーJク	PUSHING LEVER SHAFT	
26	151018001	1	ヒモアンナイオシレバーB	GIMP GUIDE PUSHING LEVER (B)	
27	018401222	1	アナボルト4X12	BOLT, SOCKET M4X12	
28	145397001	1	ヒモアンナイフリレバーA	GIMP GUIDE ZIGZAG LEVER (A)	
29	145398101	1	ヒモアンナイフリレバーB	GIMP GUIDE ZIGZAG LEVER (B)	
30	018400832	1	アナボルト4X8	BOLT, SOCKET M4X8	
31	145399001	1	オシボウ	SHAFT	
32	145400009	1	ヒモアンナイキリカエレバー	GIMP GUIDE TRANSFER LEVER	
33	115493002	1	ダンネジ5.95	STUD SCREW 5.95	
34	145401001	1	ヒモアンナイフリレバーアテ	GIMP GUIDE ZIGZAG LEVER STOPPER	
35	062680812	2	ナベコ437-40X8	SCREW, PAN M4.37-40X8	
36	145402009	1	ヒモアンナイイチカムダイ	GIMP GUIDE POSITION BRACKET	
37	145403001	1	ヒモアンナイイチカム	GIMP GUIDE POSITIONER	
38	060670612	2	バインド357-40X6	SCREW, BIND M3.57-40X6	
39	145404001	2	イチチヨウセツネジササエ	ADJUST SCREW SUPPORT	
40	102850002	2	シメネジ3.57	SCREW 3.57	
41	145405001	1	イチチヨウセツネジ	ADJUST SCREW	
42	145406001	1	レバーウケ	LEVER SUPPORT	
43	062670812	1	ナベコ3.57-40X8	SCREW, PAN M3.57-40X8	

R. タテ軸・下軸関係/Vertical shaft and lower shaft mechanism/
 ArmwellenUndGreifermechanismus/Mécanisme de l'axe de bras et de l'axe du crochet
 rotarif/Mecanismo del eje del cangrejo y eje de la transmisión superior

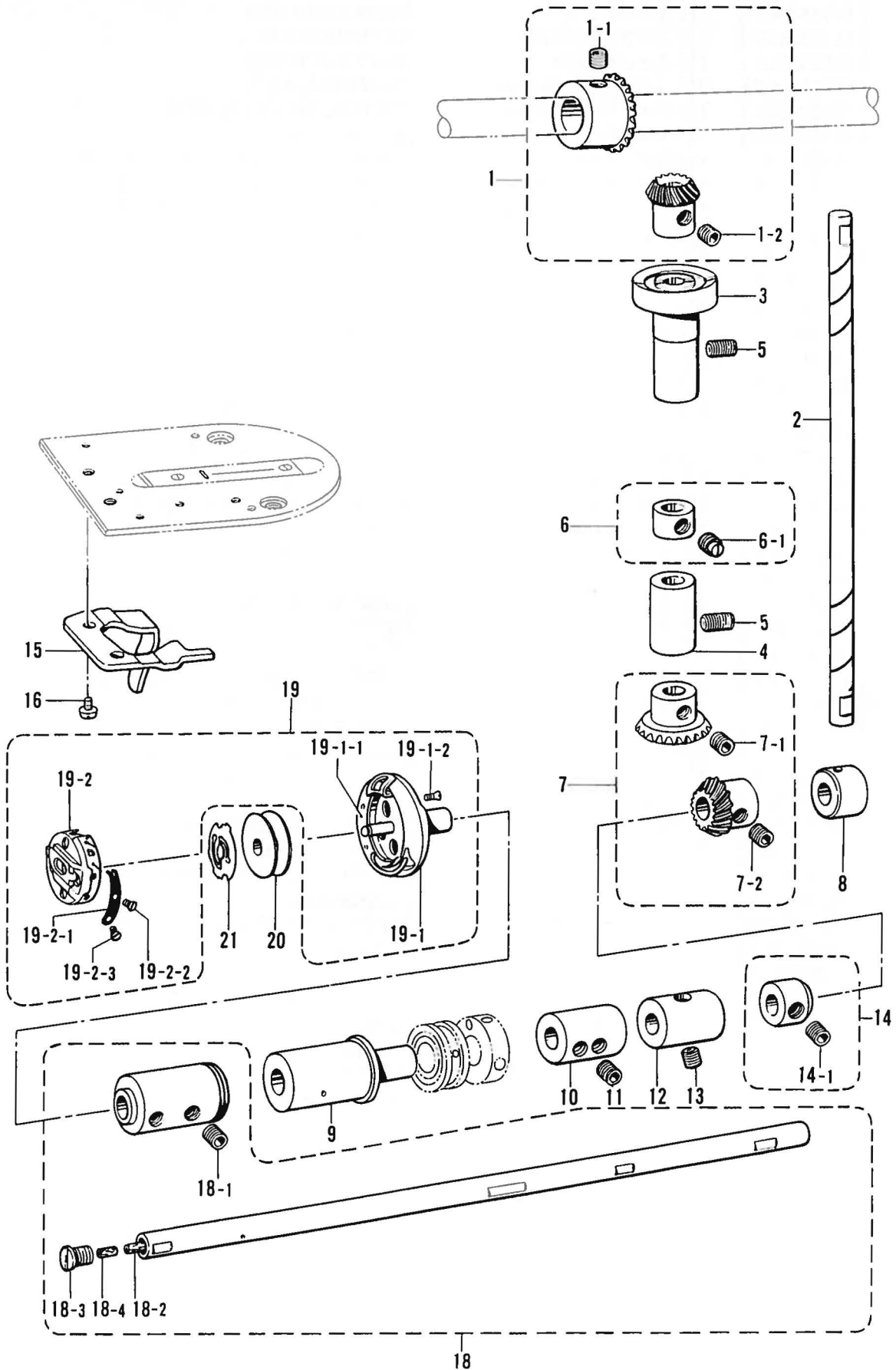

R. タテ軸・下軸関係/Vertical shaft and lower shaft mechanism/

ArmwellenUndGreifermechanismus/Mécanisme de l'axe de bras et de l'axe du crochet
rotarif/Mecanismo del eje del cangrejo y eje de la transmisión superior

REF.NO.	CODE	Q'TY	ヒンメイ	NAME OF PARTS	RM
1	181092001	1	ベベルギヤUクミ	BEVEL GEAR (U) ASSY	
1-1	014770622	2	アナトメネジ6.35クボミ	SET SCREW, SOCKET (CP) M6.35	
1-2	014770622	2	アナトメネジ6.35クボミ	SET SCREW, SOCKET (CP) M6.35	
2	141297101	1	タテジク	VERTICAL SHAFT	
3	141298000	1	タテジクメタルU	VERTICAL SHAFT BUSH (U)	
4	109208001	1	タテジクメタルD	VERTICAL SHAFT BUSH (D)	
5	013761410	2	トメネジ5.95クボミ	SET SCREW, (CP) M5.95	
6	183827001	1	セツトカラークミ	SET COLLAR ASSY	
6-1	014770622	2	アナトメネジ6.35クボミ	SET SCREW, SOCKET (CP) M6.35	
7	181093101	1	ベベルギヤDクミ	BEVEL GEAR (D) ASSY	
7-1	014770622	2	アナトメネジ6.35クボミ	SET SCREW, SOCKET (CP) M6.35	
7-2	014770622	2	アナトメネジ6.35クボミ	SET SCREW, SOCKET (CP) M6.35	
8	141303000	1	シタジクメタルB	LOWER SHAFT BUSH (B)	
9	146355001	1	シタジクメタルF	LOWER SHAFT BUSH (F)	
10	141304001	1	シタジクセツトカラーフ	LOWER SHAFT SET COLLAR (F)	
11	014770622	4	アナトメネジ6.35クボミ	SET SCREW, SOCKET (CP) M6.35	
12	141305000	1	シタジクメタルM	LOWER SHAFT BUSH (M)	
13	013771410	1	トメネジ6.35クボミ	SET SCREW, (CP) M6.35	
14	118759001	1	セツトカラークミ	SET COLLAR ASSY	
14-1	014770622	2	アナトメネジ6.35クボミ	SET SCREW, SOCKET (CP) M6.35	
15	141308101	1	カマトメ	ROTARY HOOK HOLDER	
16	062680512	2	ナベコ437-40X5	SCREW, PAN M4.37-40X5	
18	143933001	1	シタジククミ	LOWER SHAFT ASSY	
18-1	143793001	4	シールトメネジ6.35-40	SET SCREW 6.35	
18-2	142744001	1	フェルト	FELT	
18-3	109173101	1	オイルアナフタネジ	OIL CAP SCREW	
18-4	147985001	1	フェルト	FELT	
20	146025001	1	ボビン	BOBBIN	
21	148054001	1	ボビンオサエバネ	SPRING,PLATE	
			<-2,-4,-5>		
19	533031001	1	カマボビンケースクミB	ROTARY HOOK AND BOBBIN CASE ASSY (B)	
19-1	533032001	1	カマクミB	ROTARY HOOK ASSY (B)	
19-1-1	183880001	1	ナカカマオサエ	INNER ROTARY HOOK PRESSER	
19-1-2	183038001	3	ナカカマオサエシメネジ	INNER ROTARY HOOK PRESSER SCREW	
19-2	107097101	1	ボビンケースクミ	BOBBIN CASE ASSY	
19-2-1	180720001	1	ボビンケースチヨウシバネ	TENSION SPRING,PLATE	
19-2-2	180721001	1	チヨウシバネシメネジ	SCREW	
19-2-3	183507001	1	チヨウシネジ	ADJUST SCREW	
			<-3>		
19	143986101	1	カマボビンケースクミA	ROTARY HOOK AND BOBBIN CASE ASSY (A)	
19-1	141307001	1	カマクミ	ROTARY HOOK ASSY	
19-1-1	183039001	1	ナカカマオサエ	INNER ROTARY HOOK PRESSER	
19-1-2	183038001	3	ナカカマオサエシメネジ	INNER ROTARY HOOK PRESSER SCREW	
19-2	107097101	1	ボビンケースクミ	BOBBIN CASE ASSY	
19-2-1	180720001	1	ボビンケースチヨウシバネ	TENSION SPRING,PLATE	
19-2-2	180721001	1	チヨウシバネシメネジ	SCREW	
19-2-3	183507001	1	チヨウシネジ	ADJUST SCREW	

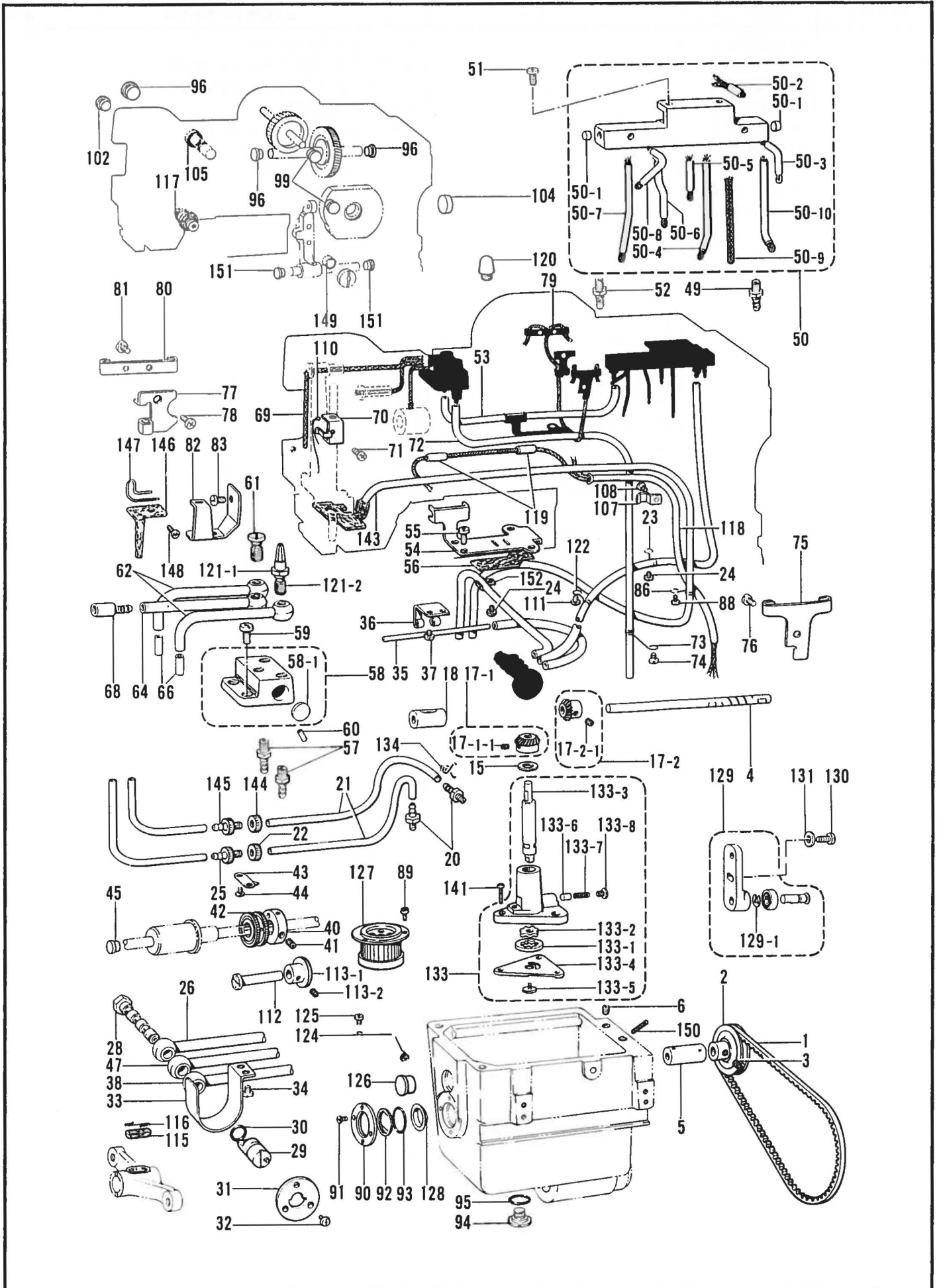

S. 給油潤滑関係/Lubrication/Schmierung/Lubrification/Lubricación

REF.NO.	CODE	Q'TY	ヒンメイ	NAME OF PARTS	RM
1	141636000	1	Vベルト	BELT, V	
2	141637000	1	オイルポンププーリ	OIL PUMP PULLEY	
3	100251001	2	トメネジ6.35	SET SCREW, M6.35	
4	143982001	1	ポンププーリジク	PUMP PULLEY SHAFT	
5	142766001	1	ポンププーリジクメタル	PUMP PULLEY SHAFT BUSH	
6	014760622	1	アナトメネジ5.95	SET SCREW, SOCKET (CP) M5.95	
15	107153001	1	ザガネ	WASHER	
17	143915001	1	ベベルギヤDクミ	BEVEL GEAR (D) ASSY	
17-1	143916001	1	ベベルギヤDクミ	PUMP SHAFT GEAR ASSY	
17-1-1	014770622	2	アナトメネジ6.35クボミ	SET SCREW, SOCKET (CP) M6.35	
17-2	180515001	1	ベベルギヤDクミ	BEVEL GEAR (D) ASSY	
17-2-1	014770622	2	アナトメネジ6.35クボミ	SET SCREW, SOCKET (CP) M6.35	
18	143983001	1	ポンプメタルF	PUMP BUSH (F)	
20	142359001	2	オイルクチ	OIL FEEDING PIPE	
21	141647000	2	ビニルチューブ (L = 190)	OIL TUBE (L = 190)	
22	142750001	1	ツギテナット	NUT	
23	112744001	1	クミヒモササエ	WICK SUPPORT	
24	062670512	2	ナベコ357-40X5	SCREW, PAN M3.57-40X5	
25	142748001	1	ビニルチューブツギテ	OIL TUBE JOINT	
26	142351101	1	ビニルチューブクミ	OIL TUBE ASSY	
28	141651001	1	オイルパイプツギテナジ	OIL FEEDING PIPE SCREW	
29	141652001	1	オイルチヨウセツタイ	OIL ADJUST BRACKET	
30	104564001	1	Oリング	O RING	
31	141653001	1	オイルチヨウセツフタ	CAP PLATE	
32	062670812	3	ナベコ3.57-40X8	SCREW, PAN M3.57-40X8	
33	141654001	1	オイルチヨウセツタイカバー	COVER	
34	062670612	2	ナベコ357-40X6	SCREW, PAN M3.57-40X6	
35	141655000	1	カマオイルパイプ	ROTARY HOOK OIL PIPE	
36	141656001	1	カマオイルパイプササエ	OIL PIPE HOLDER	
37	062670612	2	ナベコ357-40X6	SCREW, PAN M3.57-40X6	
38	142352101	1	ビニルチューブクミ	OIL TUBE ASSY	
40	109183001	1	リングオサエ	RING HOLDER	
41	013670712	2	トメネジ3.57クボミ	SET SCREW, (CP) M3.57	
42	142407001	1	オイルチヨウセツリング	OIL ADJUST RING	
43	109862001	1	チヨウセツリングトメバネ	SPRING, PLATE	
44	062670512	2	ナベコ357-40X5	SCREW, PAN M3.57-40X5	
45	104833009	1	メクラセン	OIL CAP	
47	142353101	1	ビニルチューブクミ	OIL TUBE ASSY	
49	142359001	1	オイルクチ	OIL FEEDING PIPE	
50	141661001	1	トウシンベースクミ	WICK BASE ASSY	
50-1	110104000	2	メクラセン	OIL CAP	
50-2	141663001	1	オイルパイプA	OIL TUBE (A)	
50-3	141664001	1	オイルパイプB	OIL TUBE (B)	
50-4	141665001	1	オイルパイプC	OIL TUBE (C)	
50-5	116968001	1	オイルパイプ	OIL TUBE	
50-6	141666001	1	オイルパイプE	OIL TUBE (E)	
50-7	141667001	1	オイルパイプF	OIL TUBE (F)	
50-8	141668001	1	オイルパイプG	OIL TUBE (G)	
50-9	141669000	1	クミヒモ	WICK	
50-10	150396001	1	オイルパイプH	OIL TUBE (H)	
51	062670812	2	ナベコ3.57-40X8	SCREW, PAN M3.57-40X8	
52	142359001	1	オイルクチ	OIL FEEDING PIPE	
53	141670000	1	ビニルチューブ (L = 230)	OIL TUBE (L = 230)	
54	141671001	1	ビニルパイプオサエ	VINYL TUBE HOLDER	
55	062670812	2	ナベコ3.57-40X8	SCREW, PAN M3.57-40X8	
56	141672000	1	ビニールチューブフェルト	FELT	
57	142359001	2	オイルクチ	OIL FEEDING PIPE	
58	142413001	1	トウシンベース2クミ	WICK BASE ASSY (2)	
58-1	141674001	1	トウシンベースフタ	WICK BASE CAP	

S. 給油潤滑關係/Lubrication/Schmierung/Lubrification/Lubricación

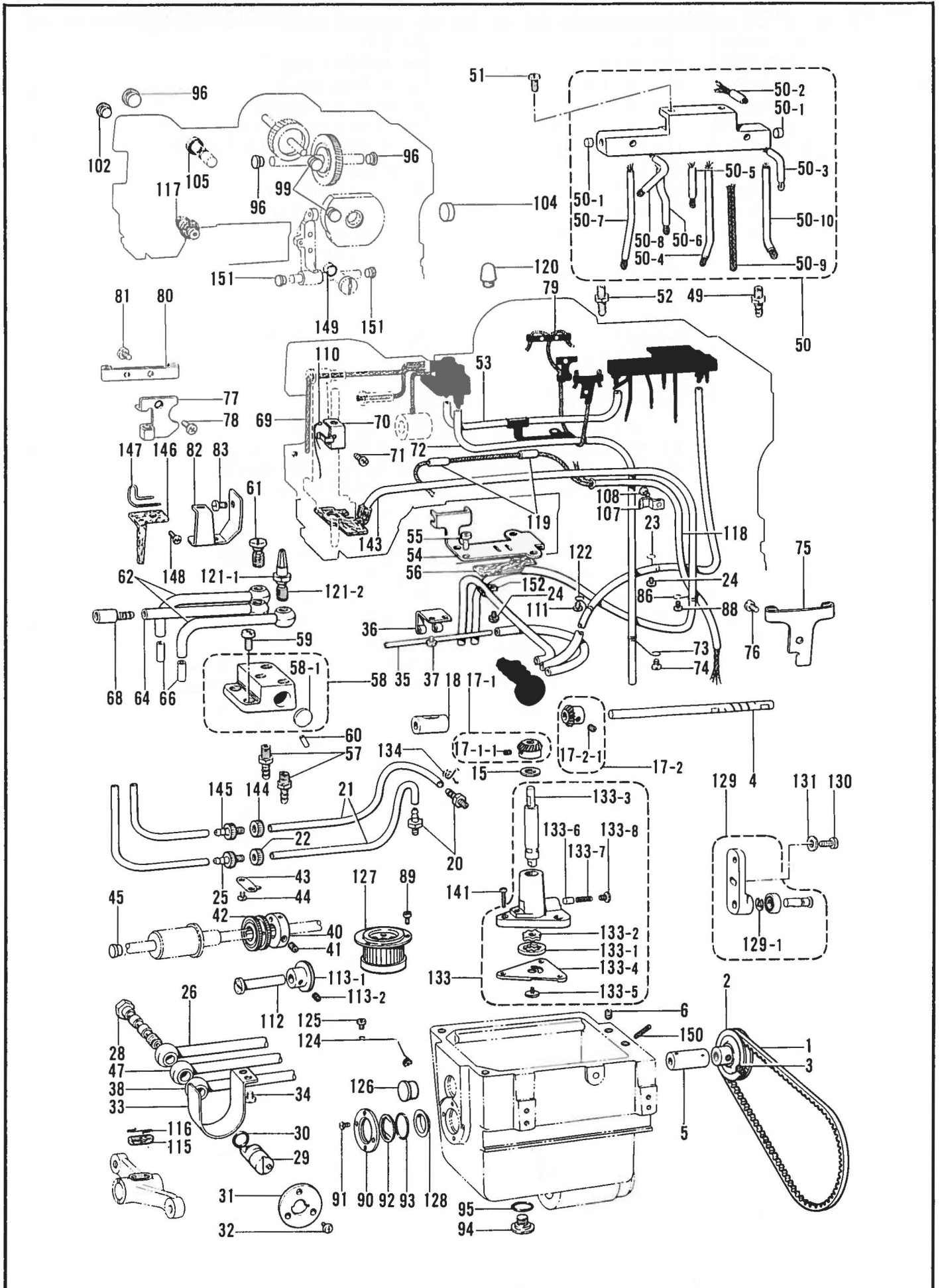

118-817-350

S. 給油潤滑関係/Lubrication/Schmierung/Lubrification/Lubricación

REF.NO.	CODE	Q'TY	ヒンメイ	NAME OF PARTS	RM
59	062670812	2	ナベコ3.57-40XB	SCREW, PAN M3.57-40X8	
60	047161042	1	スプリングピンAW1.6	PIN, SPRING ROLL AW1.6	
61	112359001	2	ハイユバイブツギテネジ	OIL FEEDING PIPE JOINT SCREW	
62	142354101	2	ビニルチューブクミ	OIL TUBE ASSY	
64	142355101	1	ビニルチューブクミ	OIL TUBE ASSY	
66	141679001	2	ダイ2オイルバイブB	VINYL TUBE (B)	
68	141680001	1	オイルクチB	OIL FEEDING PIPE (B)	
69	141681000	1	クミヒモ	WICK	
70	141682001	1	ハリボウダイトウシンササエ	WICK HOLDER	
71	062660412	1	ナベコ318-40X4	SCREW, PAN M3.18-40X4	
72	141683000	1	ビニルチューブ (L = 420)	OIL TUBE (L = 420)	
73	116975001	1	オイルチューブホルダ	OIL TUBE SUPPORT	
74	062670512	1	ナベコ357-40X5	SCREW, PAN M3.57-40X5	
75	141685001	1	トウシンオサエカネA	WICK HOLDER (A)	
76	062680612	1	ナベコ4.37-40X6	SCREW, PAN M4.37-40X6	
77	141686001	1	トウシンオサエカネB	WICK HOLDER (B)	
78	062680612	1	ナベコ4.37-40X6	SCREW, PAN M4.37-40X6	
79	141687000	2	クミヒモ	WICK	
80	141688001	1	トウシンオサエカネC	WICK HOLDER (C)	
81	S01297001	2	シメネジ3.57X3.5	SCREW 3.57X3.5	
82	141689101	1	トウシンオサエカネD	WICK HOLDER (D)	
83	107419002	1	シメネジ4.37	SCREW 4.37	
86	141692001	1	ビニルチューブササエC	TUBE SUPPORT (C)	
88	062670512	1	ナベコ357-40X5	SCREW, PAN M3.57-40X5	
89	062680712	3	ナベコ437-40X7	SCREW, PAN M4.37-40X7	
90	151074009	1	ユリヨウケイフタ	OIL GAUGE COVER	
91	100257010	4	シメネジ3.57	SCREW 3.57	
92	141696001	1	オイルゲージマド	OIL GAUGE WINDOW	
93	081014670	1	OリングPW14	O RING, PW11	
94	110641002	1	ダンネジ9.52	STUD SCREW 9.52	
95	109203001	1	Oリング	O RING	
96	104449009	3	メクラセン	OIL CAP	
99	104821009	2	メクラセン	OIL CAP	
102	104450109	2	メクラセン	OIL CAP	
104	116725009	1	メクラセン	OIL CAP	
105	141697000	1	Oリング	O RING	
107	142268001	1	コードオサエL	CORD HOLDER (L)	
108	062670512	1	ナベコ357-40X5	SCREW, PAN M3.57-40X5	
110	142298000	1	クミヒモ (L = 70)	WICK (L = 70)	
111	062670512	1	ナベコ357-40X5	SCREW, PAN M3.57-40X5	
112	142408001	1	オイルチヨウセツジク	OIL ADJUST STUD	
113	183706001	1	オイルチヨウセツギヤクミ	OIL ADJUST GEAR ASSY	
113-1	142582001	1	オイルチヨウセツギヤ	OIL ADJUST GEAR	
113-2	151602002	2	トメネジ4.37	SET SCREW, M4.37	
115	117598001	1	フェルト	FELT	
116	116795000	1	クリツブ	CLIP	
117	114294001	1	Oリング	O RING	
118	142742000	1	ビニルチューブ (L = 190)	OIL TUBE (L = 190)	
119	120774001	2	ビニルチューブ (L = 20)	OIL TUBE (L = 20)	
120	143713101	1	オイルキャップ	OIL CAP	
121	143714001	1	ゲージバイブクミ	OIL GAUGE WINDOW PIPE ASSY	
121-1	143715001	1	ゲージバイブ	PIPE FOR OIL GAUGE WINDOW	
121-2	143716001	1	ゲージバイブネジ	GAUGE PIPE SCREW	
122	112743001	1	クミヒモササエ	WICK SUPPORT	
124	116975001	1	オイルチューブホルダ	OIL TUBE STOPPER	
125	060670616	1	バインド357-40X6	SCREW, BIND M3.57-40X6	
126	108520009	1	メクラセン	OIL CAP	
127	146209101	1	フィルタークミ	OIL FILTER ASSY	
128	147226001	1	オイルハンシヤバン	OIL PLATE	

S. 給油潤滑關係/Lubrication/Schmierung/Lubrification/Lubricación

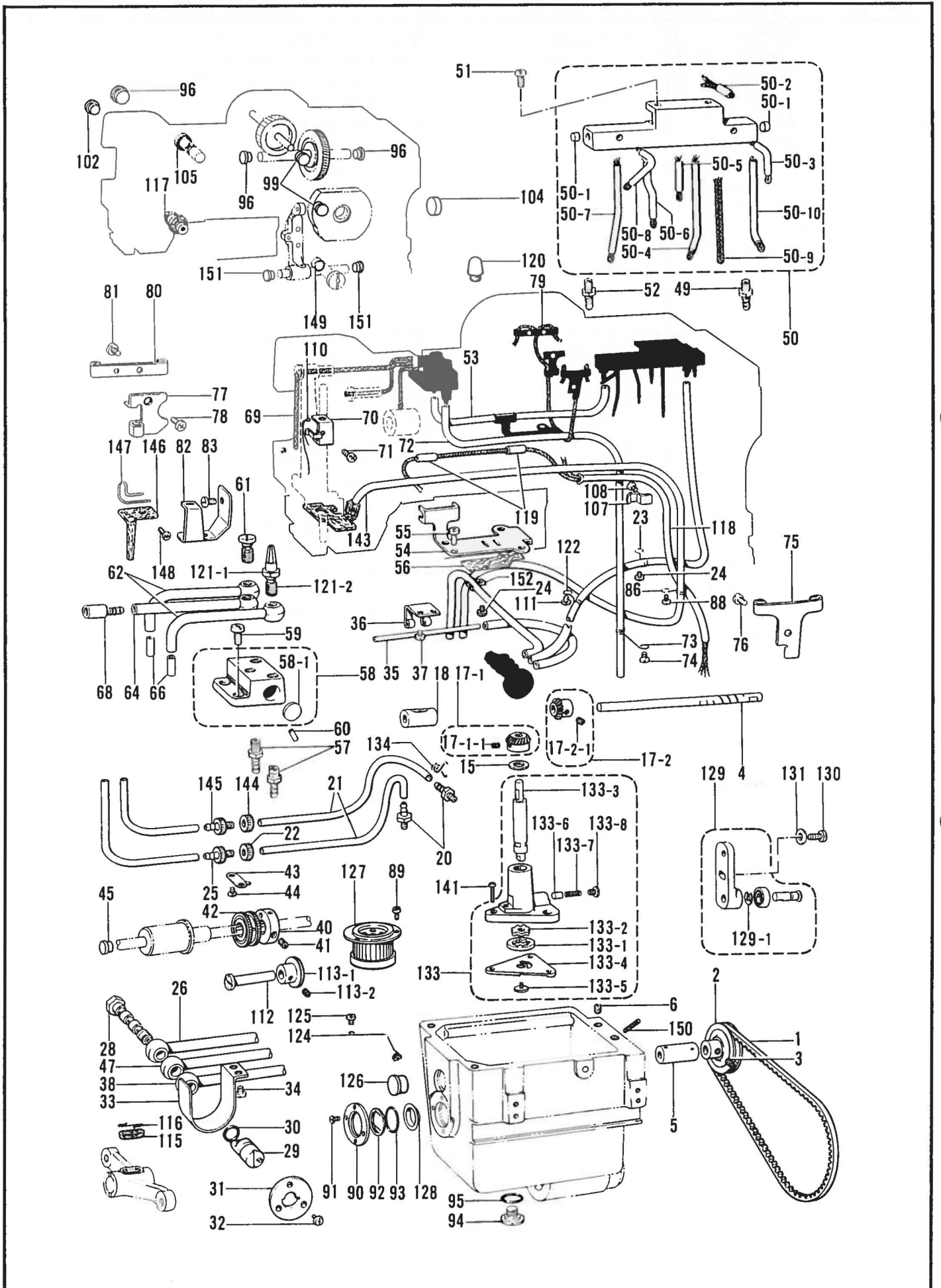

S. 給油潤滑関係/Lubrication/Schmierung/Lubrification/Lubricación

REF.NO.	CODE	Q'TY	ヒンメイ	NAME OF PARTS	RM
129	147223001	1	ポンプベルトハリクミ	PUMP BELT TENSION LEVER ASSY	
129-1	048060342	1	トメワE6	RETAINING RING, E6	
130	062761212	1	ナベコ595-28X12	SCREW, PAN M5.95-28X12	
131	025060232	1	ヒラザガネチユウ6	WASHER, PLAIN M 6	
133	148761001	1	ポンプクミ	PUMP ASSY	
133-1	141642000	1	オイルポンプアウターロータ	OIL PUMP OUTER ROTOR	
133-2	141643000	1	オイルポンプインナーロータ	OIL PUMP INNER ROTOR	
133-3	148469001	1	ポンプジク	PUMP SHAFT	
133-4	148470001	1	ポンプフタ	PUMP CAP PLATE	
133-5	145465001	1	シメネジ3.57L	SCREW 3.57 (L)	
133-6	148471001	1	プランジャー	PLUNGER	
133-7	144876001	1	プランジャーバネ	PLUNGER SPRING	
133-8	112467002	1	シメネジ6.35	SCREW 6.35	
134	S07876001	1	チューブストツバー	TUBE CLIP	
141	062711412	3	ナベコ4.76-32X14	SCREW, PAN M4.76-32X14	
143	148472001	1	チューブクミ	OIL TUBE ASSY	
144	142750002	1	ツギテナット	NUT	
145	142748002	1	ビニルチューブツギテ	OIL TUBE JOINT	
146	148745000	1	フェルト	FELT	
147	148746001	1	フェルトオサエ	FELT SUPPORT	
148	062680612	1	ナベコ4.37-40X6	SCREW, PAN M4.37-40X6	
149	141697000	1	Oリング	O RING	
150	183120000	1	クミヒモ	WICK	
151	158437009	2	メクラセン	OIL CAP	
152	140647001	1	コードオサエ	CORD HOLDER	

118-817-350

T. 糸通シ関係/Threading mechanism/Fadenführungs-vorrichtung/
 Mécanisme de l'enfilage/Mecanismo del enhebrado

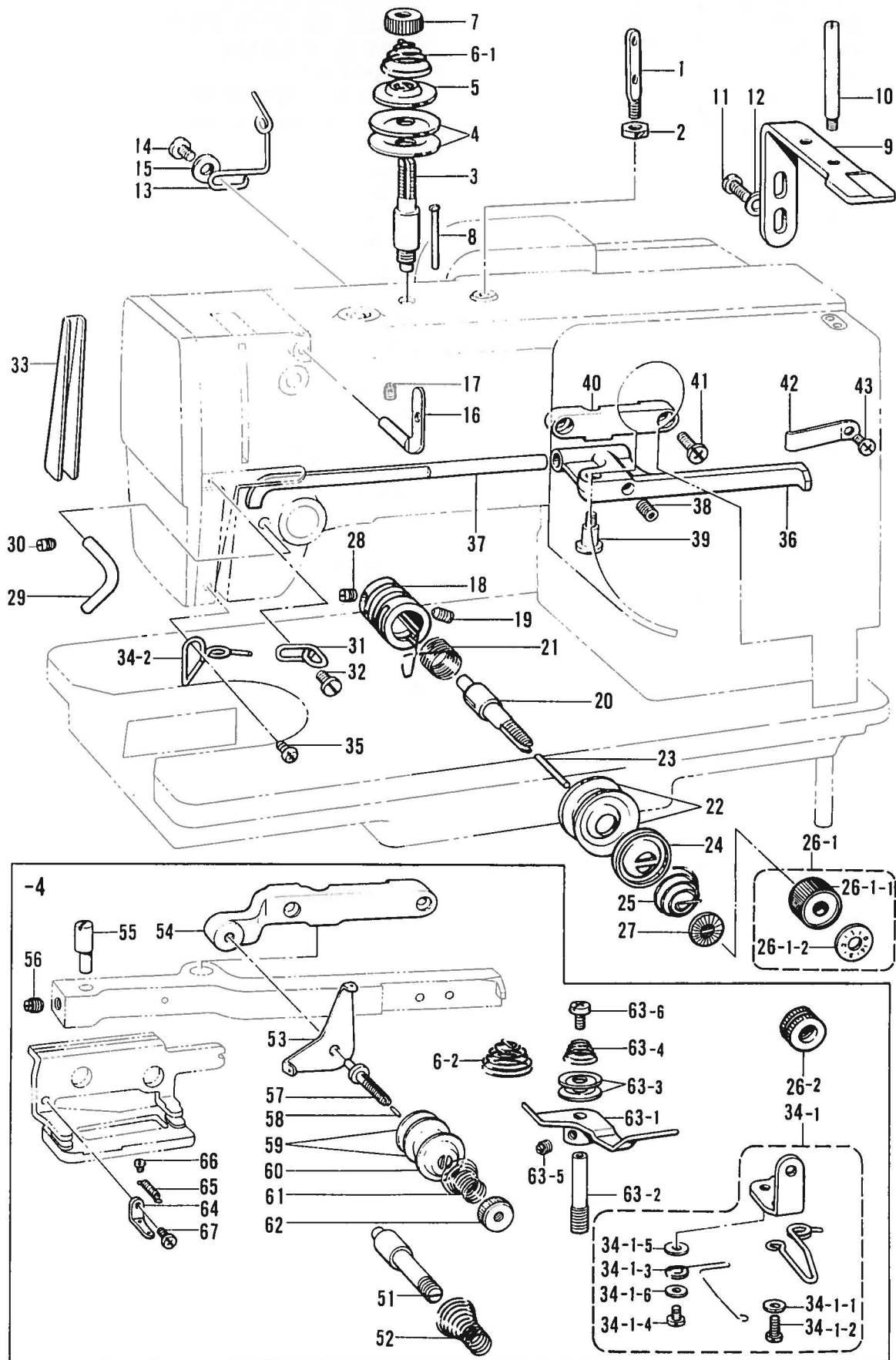

T. 糸通シ関係/Threading mechanism/FadenführungsVorrichtung/
Mécánisme de lénfilage/Mecanismo del enhebrado

REF.NO.	CODE	Q'TY	ヒンメイ	NAME OF PARTS	RM
2	150553003	1	ナツト5.95	NUT 5.95	
3	107602001	1	イトチヨウシボウ	TENSION STUD	
4	145446001	2	イトチヨウシサラ	TENSION DISC	
5	159805001	1	イトチヨウシサラオサエ	TENSION DISC PRESSER	
7	100136001	1	イトチヨウシナツト	TENSION NUT	
8	107612001	1	イトチヨウシイトユルメピン	PIN	
9	145673001	1	ウワイトユルメイタ	UPPER THREAD RELEASE PLATE	
10	141592001	1	ウワイトトリボウ	UPPER THREAD GUIDE SHAFT	
11	062680812	2	ナベコ437-40X8	SCREW, PAN M4.37-40X8	
12	025680232	2	ヒラザガネチユウ4.37	WASHER, PLAIN M 4.37	
13	141593001	1	ウワイトトオシ	UPPER THREAD GUIDE	
14	100644005	1	シメネジ4.37	SCREW 4.37	
15	025680232	1	ヒラザガネチユウ4.37	WASHER, PLAIN M 4.37	
16	145961001	1	ヒトツメイトカケ	THREAD RETAINER	
17	151602002	1	トメネジ4.37	SET SCREW, M4.37	
18	144741001	1	イトチヨウシボウタイ	THREAD TENSION BRACKET	
19	103950003	1	トメネジ5.95	SET SCREW, M5.95	
21	100399001	1	イトトリバネ	SPRING	
22	145446001	2	イトチヨウシサラ	TENSION DISC	
28	100402004	1	トメネジ3.57	SET SCREW, M3.57	
29	142733001	1	イトアンナイ	TENSION THREAD GUIDE	
30	013711010	1	トメネジ4.76クボミ	SET SCREW, (CP) M4.76	
31	142735001	2	アームイトカケ	ARM THREAD GUIDE (UPPER)	
32	112751003	2	シメネジ3.57	SCREW 3.57	
33	141594001	1	アームイトミチ	ARM THREAD GUIDE	
35	060670512	1	バインド357-40X5	SCREW, BIND M3.57-40X5	
41	062681012	2	ナベコ437-40X10	SCREW, PAN M4.37-40X10	
42	142258001	1	イトユルメレバーイタバネ	PLATE SPRING	
43	062670512	1	ナベコ357-40X5	SCREW, PAN M3.57-40X5	

118-817-401

T. 糸通シ関係/Threading mechanism/FadenführungsVorrichtung/
Mécánisme de lénfilage/Mecanismo del enhebrado

REF.NO.	CODE	Q'TY	ヒンメイ	NAME OF PARTS	RM
			<-2,-3,-5>		
1	141590001	1	イトトオシボウ	THREADING BAR (U)	
6-1	115188001	1	シユイトチヨウシバネ	TENSION SPRING	
20	100398001	1	イトチヨウシボウ	TENSION STUD	
23	100400000	1	イトユルメピン	PIN	
24	159805001	1	イトチヨウシサラオサエ	TENSION DISC PRESSER	
25	107606001	1	イトチヨウシバネ	TENSION SPRING	
26-1	S11182009	1	イトチヨウシナツトクミ	THREAD TENSION NUT ASSY	
26-1-1	S11183009	1	チヨウセツツマミ	CONTROL DIAL	
26-1-2	S11184009	1	イトチヨウシメモリアタ	TENSION ADJUST SCALE PLATE	
27	S02624001	1	チヨウシバネウエザガネ	WASHER	
34-2	S33002001	1	アームイトアンナイシタ	ARM THREAD GUIDE LOWER	
36	141596009	1	ウワイトユルメレバー	UPPER THREAD RELEASE LEVER	
37	141597001	1	ウワイトユルメボウ	UPPER THREAD RELEASE SHAFT	
38	014760622	1	アナトメネジ5.95	SET SCREW, SOCKET (CP) M5.95	
39	141598001	1	ダンネジ4.76	STUD SCREW 4.76	
40	141599009	1	ウワイトユルメレバーダイ	UPPER THREAD RELEASE LEVER BRACKET	
			<-4>		
6-2	117215001	1	イトチヨウシバネ	TENSION SPRING	
26-2	100136001	1	イトチヨウシナツト	TENSION NUT	
34-1	148831001	1	サブテンションクミ	SUB TENSION ASSY	
34-1-1	105161004	1	ザガネ	WASHER	
34-1-2	062670612	1	ナベコ357-40X6	SCREW, PAN M3.57-40X6	
34-1-3	148058001	1	サブテンションバネ	SPRING	
34-1-4	062670412	1	ナベコ357-40X4	SCREW, PAN M3.57-40X4	
34-1-5	400806003	1	ザガネ	WASHER	
34-1-6	025350132	1	ヒラザガネシヨウ	WASHER, PLAIN S 3.5	
51	145437001	1	イトチヨウシボウ	TENSION STUD	
52	115958001	1	ULイトチヨウシバネ	TENSION SPRING (UL)	
53	110813001	1	ハリイトアンナイ	NEEDLE THREAD GUIDE	
54	145438009	1	ヒモチヨウシダイ	GIMP TENSION BRACKET	
55	145439001	1	ヒモユルメピン	PIN	
56	151601002	1	トメネジ4.37	SET SCREW, M4.37	
57	145440001	1	イトチヨウシボウ	TENSION STUD	
58	105423001	1	ピン	PIN	
59	145446001	2	イトチヨウシサラ	TENSION DISC	
60	159805001	1	イトチヨウシサラオサエ	TENSION DISC PRESSER	
61	115958001	1	ULイトチヨウシバネ	TENSION SPRING (UL)	
62	100136001	1	イトチヨウシナツト	TENSION NUT	
63	145723001	1	プレテンションクミ	PRE-TENSION ASSY	
63-1	145724001	1	プレテンションタイ	PRE-TENSION BODY	
63-2	145725001	1	プレテンションジク	PRE-TENSION SHAFT	
63-3	144504001	2	イトアンナイサラ	THREAD GUIDE DISC	
63-4	144505000	1	イトアンナイバネ	SPRING	
63-5	102716003	1	ランブツマミトメネジ	SET SCREW	
63-6	060660516	1	バインド318-40X5	SCREW, BIND M3.18-40X5	
64	145991001	1	ヒモカケダイ	GIMP STOPPER	
65	511091001	1	ヒキバネ	SPRING, EXTENSION	
66	122771002	2	シメネジ2.38	SCREW 2.38	
67	062660412	1	ナベコ318-40X4	SCREW, PAN M3.18-40X4	

U . 糸巻関係/Bobbin winder/Spuler/Mécanisme du bobineur/
Mecanismo del devanador de la canilla

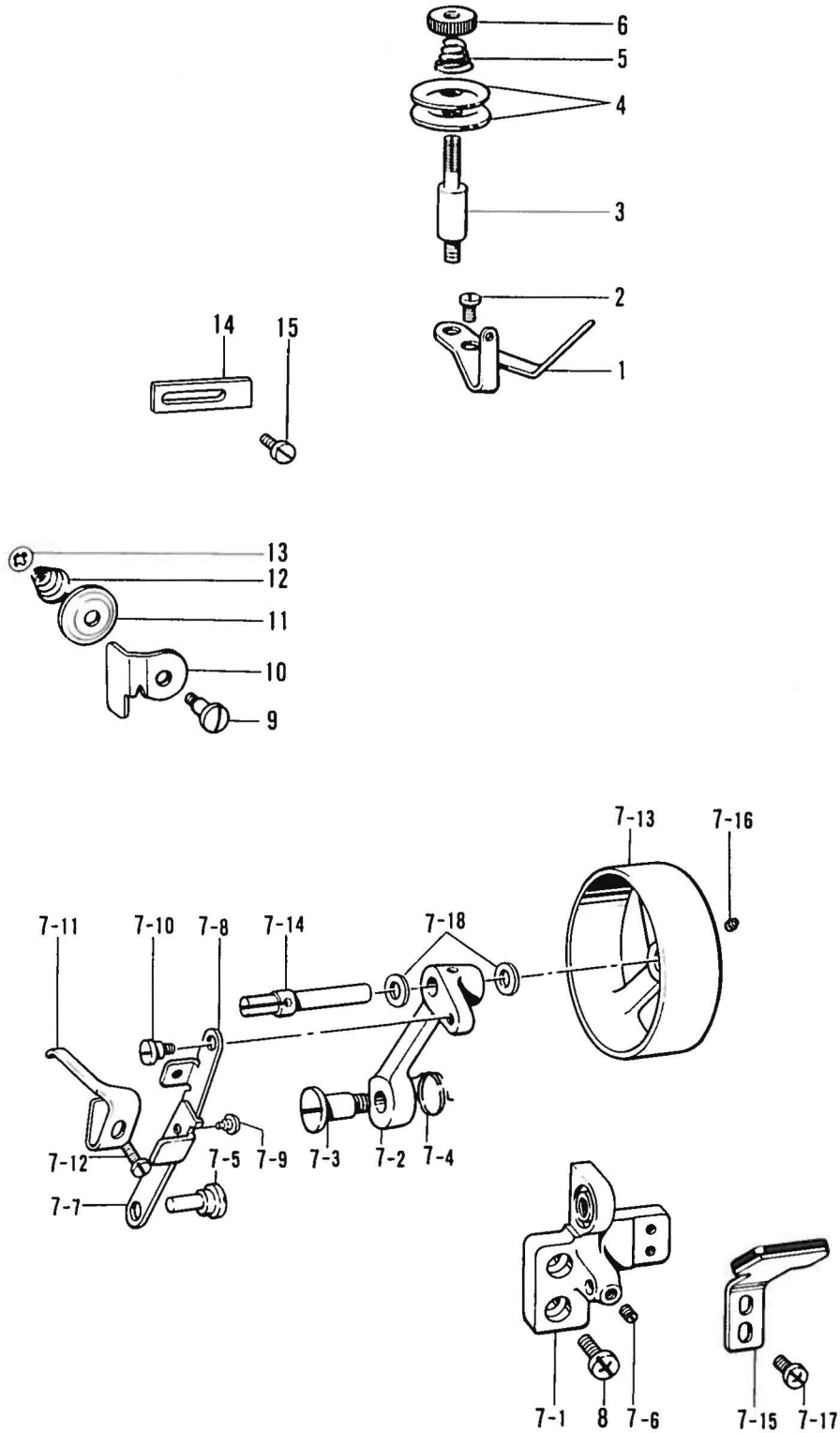

U. 糸巻関係/Bobbin winder/Spuler/Mécanisme du bobineur/
Mecanismo del devanador de la canilla

REF. NO.	CODE	Q'TY	ヒンメイ	NAME OF PARTS	RM
1	141600001	1	イトマキチヨウシアンナイ	BOBBIN WINDER THREAD GUIDE	
2	107407003	1	シメネジ4.37	SCREW 4.37	
3	107678101	1	イトマキイトチヨウシボウ	TENSION STUD	
4	107680001	2	イトマキイトチヨウシサラ	TENSION DISC	
5	107681001	1	イトマキイトチヨウシバネ	TENSION SPRING	
6	107682001	1	イトマキチヨウシナツト	BOBBIN WINDER TENSION NUT	
7	141601009	1	イトマキキクミ	BOBBIN WINDER ASSY	
7-1	141602009	1	イトマキクルマダイ	BOBBIN WINDER WHEEL BRACKET	
7-2	141603009	1	イトマキクルマウデ	BOBBIN WINDER WHEEL ARM	
7-3	141604001	1	ダンネジ6.35	STUD SCREW 6.35	
7-4	142259001	1	イトマキクルマウデバネ	SPRING	
7-5	141605001	1	イトマキリンクジク	BOBBIN WINDER LINK STUD	
7-6	013679412	1	トメネジ3.57クボミ	SET SCREW, (CP) M3.57	
7-7	141606001	1	イトマキリンクA	BOBBIN WINDER LINK (A)	
7-8	141607001	1	イトマキリンクB	BOBBIN WINDER LINK (B)	
7-9	100661001	1	カシメピン	PIN	
7-10	100659001	1	ダンネジ3.18	STUD SCREW 3.18	
7-11	141608001	1	ボビンオサエ	BOBBIN PRESSER	
7-12	507142002	1	シメネジ	SCREW	
7-13	141609009	1	イトマキクルマ	BOBBIN WINDER WHEEL	
7-14	141610001	1	イトマキジク	BOBBIN WINDER SHAFT	
7-15	141611001	1	ブレーキゴムクミ	BOBBIN WINDER BRAKE RUBBER ASSY	
7-16	151601002	1	トメネジ4.37	SET SCREW, M4.37	
7-17	062680712	2	ナベコ437-40X7	SCREW, PAN M4.37-40X7	
7-18	142711001	2	ファイバーワツシヤ	WASHER	
8	062761212	2	ナベコ595-28X12	SCREW, PAN M5.95-28X12	
9	118764002	1	ダンネジ4.37	STUD SCREW 4.37	
10	146198001	1	イトツカミメス	THREAD CLAMP KNIFE	
11	146199001	1	イトツカミサラ	THREAD CLAMP DISC	
12	144505000	1	イトアンナイバネ	SPRING	
13	146200001	1	トメワCS4	RETAINING RING, CS4	
14	141620001	1	ボウシイタバランス	BALANCE	
15	101671002	1	シメネジ4.37	SCREW 4.37	

118-817-402

V1. 上糸切り関係/Upper thread trimmer mechanism/Oberer Fadenabschneider/
 Mécanisme de la coupe-fil supérieur/Mecanismo de la recortadora de orillos superior

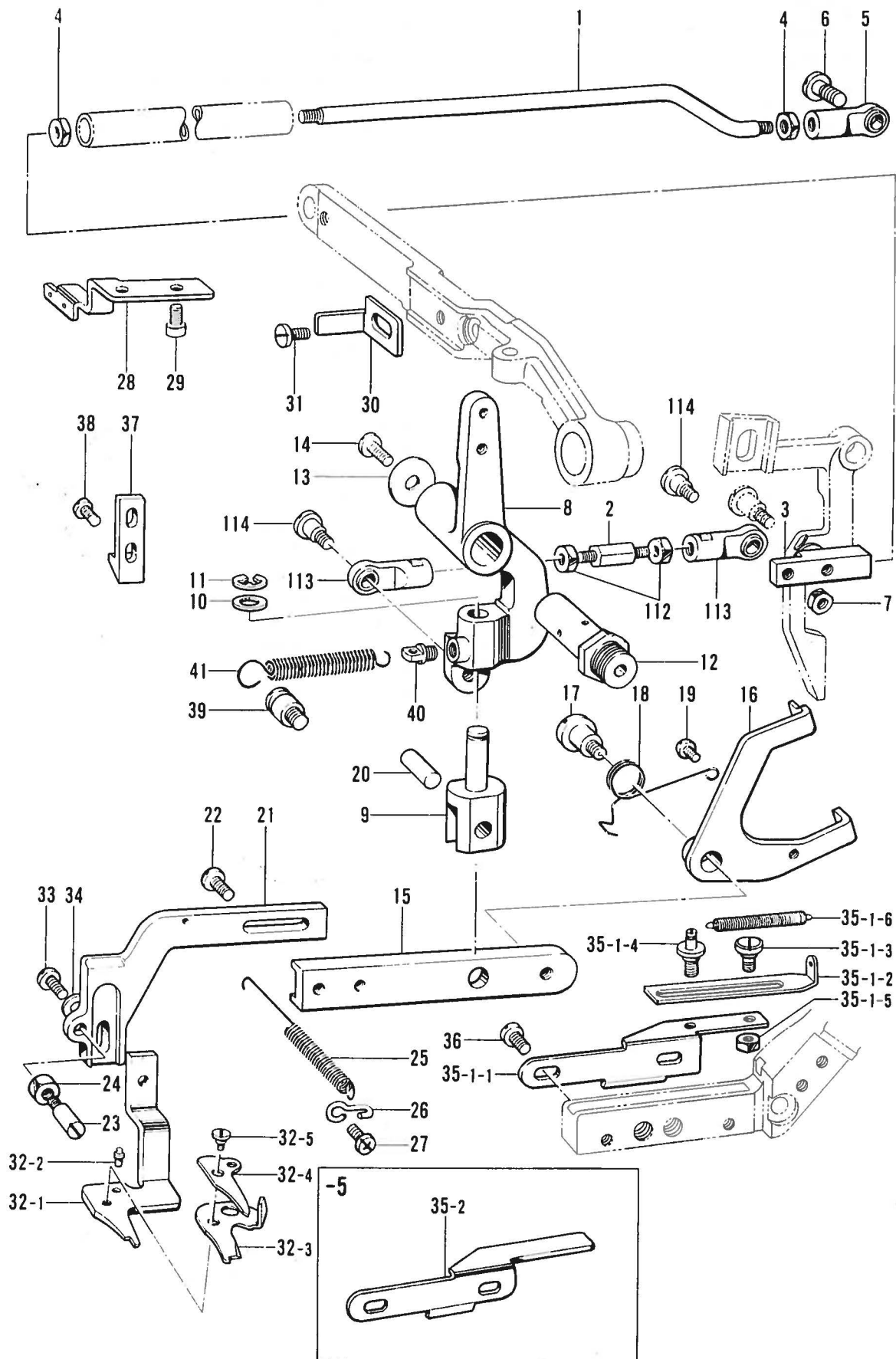

V1. 上糸切り関係/Upper thread trimmer mechanism/Oberer Fadenabschneider/
Mécanisme de la coupe-fil supérieur/Mecanismo de la recortadora de orillos superior

REF.NO.	CODE	Q'TY	ヒンメイ	NAME OF PARTS	RM
1	141489001	1	ウワイトキリレンカンL	THREAD TRIMMER CONNECTING ROD (L)	
2	141490001	1	ウワイトキリレンカンS	THREAD TRIMMER CONNECTING ROD (S)	
3	141491001	1	ウワイトキリレンカンツギテ	THREAD TRIMMER CONNECTING ROD JOINT	
4	100022005	2	ナツト5.95	NUT 5.95	
5	141492001	1	タマツギテクミ	JOINT ASSY	
6	141494001	1	タマツギテダンネジ	STUD SCREW	
7	100022005	1	ナツト5.95	NUT 5.95	
8	147565001	1	ウワイトキリレバーササエ	UPPER THREAD TRIMMER LEVER SUPPORT	
10	100281001	1	ザガネ	WASHER	
11	048060342	1	トメワE6	RETAINING RING, E6	
12	141463001	1	カッタサドウレバージク	STUD	
13	149095001	1	ザガネ	WASHER	
14	062761212	1	ナベコ595-28X12	SCREW, PAN M5.95-28X12	
38	062681012	2	ナベコ437-40X10	SCREW, PAN M4.37-40X10	
40	107639001	1	バネカケU	SPRING HOOK (U)	
112	100022005	2	ナツト5.95	NUT 5.95	
113	141492001	2	タマツギテクミ	JOINT ASSY	
114	141494001	2	タマツギテダンネジ	STUD SCREW	

9	141496001	1	<-2,-3,-5> ウワイトキリヒンジ	UPPER THREAD TRIMMER HINGE	
15	141497001	1	ウワイトキリレバーL	UPPER THREAD TRIMMER LEVER (L)	
16	145998001	1	イトキリレバーサドウイタ	LEVER DRIVING POSITIONER	
17	141499001	1	ダンネジ4.76	STUD SCREW 4.76	
18	141500001	1	サドウイタネジリバネ	SPRING, TORTION	
19	062670412	1	ナベコ357-40X4	SCREW, PAN M3.57-40X4	
20	141501001	1	ウワイトキリヒンジピン	PIN	
21	141502001	1	ウワイトキリレバーS	UPPER THREAD TRIMMER LEVER (S)	
22	107407003	2	シメネジ4.37	SCREW 4.37	
23	141504001	1	イトキリレバーササエボウ	THREAD TRIMMING LEVER SUPPORT STUD	
24	110161004	1	ナツト4.76	NUT 4.76	
25	141505001	1	イトキリレバーサドウバネ	SPRING, EXTENSION	
26	141506001	1	バネカケ	SPRING HOOK	
27	062680712	1	ナベコ437-40X7	SCREW, PAN M4.37-40X7	
28	533003001	1	サドウイタストツバ	STOPPER PLATE	
29	018400832	2	アナボルト4X8	BOLT, SOCKET M4X8	
30	141508001	1	ウワイトキリハズシカネ	UPPER THREAD TRIMMER DETACH PLATE	
31	107407003	1	シメネジ4.37	SCREW 4.37	
32	141509101	1	ハサミクミ	UPPER THREAD TRIMMER ASSY	
32-1	141510101	1	ハサミD	UPPER THREAD TRIMMER (D)	
32-2	141511001	1	ハサミUストツバピン	PIN	
32-3	141512101	1	ハサミM	UPPER THREAD TRIMMER (M)	
32-4	141513001	1	ハサミウエ	UPPER THREAD TRIMMER (UPPER)	
32-5	141514001	1	ハサミダンネジ	STUD SCREW	
33	062710812	1	ナベコ476-32X8	SCREW, PAN M4.76-32X8	
34	025710232	1	ヒラザガネチユウ4.76	WASHER, PLAIN M 4.76	
36	062680712	2	ナベコ437-40X7	SCREW, PAN M4.37-40X7	
37	141516001	1	ウワイトキリハサミニゲカム	UPPER THREAD TRIMMER CAM	
39	141472002	1	シタイトキリレバーバネカケ	SPRING HOOK	
41	141517101	1	イトキリレバーササエバネ	SPRING, EXTENSION	

35-1	145999001	1	<-2,-3> ハサミアンナイクミ	THREAD TRIMMER GUIDE ASSY	
35-1-1	141515001	1	ハサミアンナイ	THREAD TRIMMER GUIDE	
35-1-2	146000001	1	ハサミササエ	THREAD TRIMMING SUPPORT	
35-1-3	146001001	1	ダンネジ3.18	STUD SCREW 3.18	
35-1-4	146002001	1	ダンネジ3.18	STUD SCREW 3.18	
35-1-5	021660102	2	ナツト1シユ3.18	NUT, 1 M3.18	
35-1-6	118352001	1	ヒキバネ	SPRING, EXTENSION	
35-2	147558001	1	<-5> ハサミアンナイ	THREAD TRIMMER GUIDE	

118-817-409

V2 . 上糸切り関係/Upper thread trimmer mechanism/Oberer Fadenabschneider/
Mécanisme de la coupe-fil supérieur/Mecanismo de la recortadora de orillos superior

-4

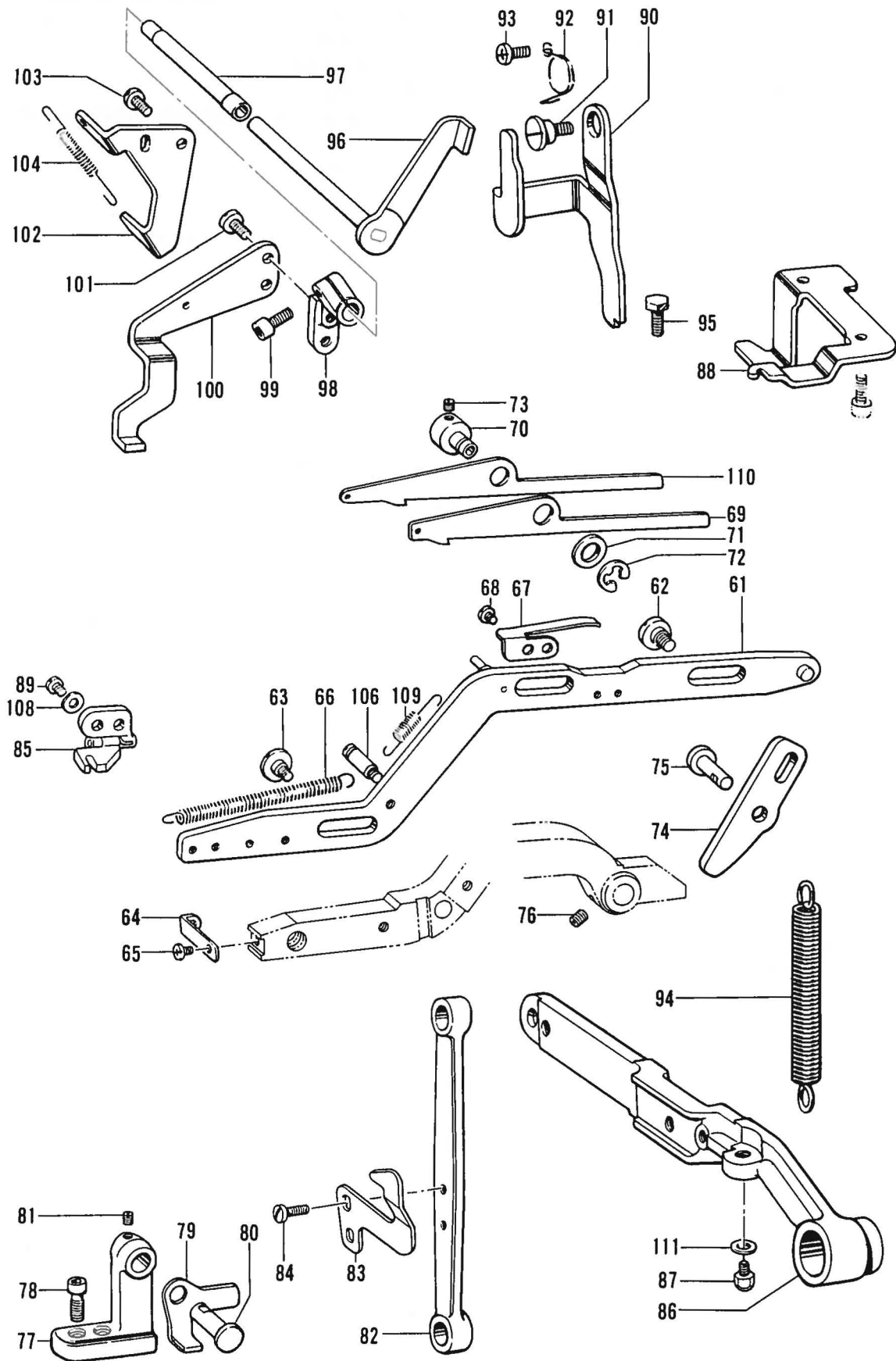

V2 . 上糸切り関係/Upper thread trimmer mechanism/Oberer Fadenabschneider/
 Mécanisme de la coupe-fil supérieur/Mecanismo de la recortadora de orillos superior

REF.NO.	CODE	Q'TY	ヒンメイ	NAME OF PARTS	RM
			<-4>		
61	145407001	1	ヒモキリカンクミ	GIMP TRIMMING CONNECTOR ASSY	
62	118244001	2	ダンネジ5.95	STUD SCREW 5.95	
63	116755001	1	ダンネジ4.37	STUD SCREW 4.37	
64	145411001	1	バネカケ	SPRING HOOK	
65	062680512	1	ナベコ437-40X5	SCREW, PAN M4.37-40X5	
66	145412001	1	ヒモキリカンモドシバネ	SPRING, EXTENSION	
67	145413001	1	ヒモキリセットバネ	SPRING, PLATE	
68	060660512	2	バインド318-40X5	SCREW, BIND M3.18-40X5	
69	145415001	1	ヒモキリセットイタ	GIMP KNIFE SET PLATE	
70	145416001	1	ヒモキリセットイタジク	GIMP KNIFE SET PLATE STUD	
71	100197002	1	ザガネ	WASHER	
72	048060342	1	トメワE6	RETAINING RING, E6	
73	151601002	1	トメネジ4.37	SET SCREW, M4.37	
74	145417001	1	ヒモキリアーム	GIMP TRIMMING ARM	
75	143788001	1	レバーストツバジク	STUD	
76	014770622	1	アナトメネジ6.35クボミ	SET SCREW, SOCKET (CP) M6.35	
77	145418009	1	ヒモキリヒキダイ	GIMP TRIMMER PULLING BRACKET	
78	018401622	2	アナボルト4X16	BOLT, SOCKET M4X16	
79	145419001	1	ヒモキリリンク	GIMP TRIMMING LINK	
80	143788001	1	レバーストツバジク	STUD	
81	151601002	1	トメネジ4.37	SET SCREW, M4.37	
82	145420001	1	タイトキリサドウレンカン	LOWER THREAD TRIMMER DRIVING ROD	
83	145421001	1	ヒモキリヒキイタ	GIMP PULLING PLATE	
84	107407003	2	シメネジ4.37	SCREW 4.37	
85	145732001	1	ヒモキリウデクミ	GIMP TRIMMING BRACKET ASSY	
86	145426009	1	オサエアゲレバー	CLAMPING FOOT LIFTER LEVER	
87	145427001	1	ボルト7.94	BOLT, M7.94	
88	145428001	1	タイトキリレバーストツバ	LOWER THREAD TRIMMER LEVER STOPPER	
89	062680612	2	ナベコ4.37-40X6	SCREW, PAN M4.37-40X6	
90	145429001	1	オサエアゲストツバ	UPPER CLAMPING FOOT LIFTER LEVER STOPPER	
91	116755001	1	ダンネジ4.37	STUD SCREW 4.37	
92	145430001	1	ストツバモドシバネ	SPRING	
93	062680612	1	ナベコ4.37-40X6	SCREW, PAN M4.37-40X6	
94	145431001	1	タイトキリレバーバネ	SPRING, EXTENSION	
95	017681012	1	ボルト4.37X10	BOLT, M4.37X10	
96	145433001	1	ハサミハズシレバ	THREAD TRIMMER DETACH LEVER	
97	145434001	1	ハズシレバーメタル	THREAD TRIMMING DETACH LEVER BUSH	
98	145435001	1	ハズシレバーダキ	DETACH LEVER HOLDER	
99	018400832	1	アナボルト4X8	BOLT, SOCKET M4X8	
100	145414001	1	ヒモキリハズシカネ	GIMP TRIMMING DETACH LEVER	
101	100644005	2	シメネジ4.37	SCREW 4.37	
102	145436001	1	ハズシカネストツバ	STOPPER	
103	060670812	2	バインド357-40X8	SCREW, BIND M3.57-40X8	
104	113897001	1	セツシヨクシリリーサバネ	SPRING, EXTENSION	
106	107657001	1	バネカケ	SPRING HOOK	
108	100645003	2	ザガネ	WASHER	
109	113897001	1	セツシヨクシリリーサバネ	SPRING, EXTENSION	
110	145983001	1	ヒモキリセーフイタ	GIMP TRIMMING SAFETY PLATE	
111	025080132	2	ヒラザガネシヨウ8	WASHER, PLAIN S 8	

118-817-409

W. 下糸切り関係/Lower thread trimmer mechanism/Unterer Fadenabschneider/
 Mécanisme de la coupe-fil inférieur/Mecanismo de la recortadora de orillos inferior

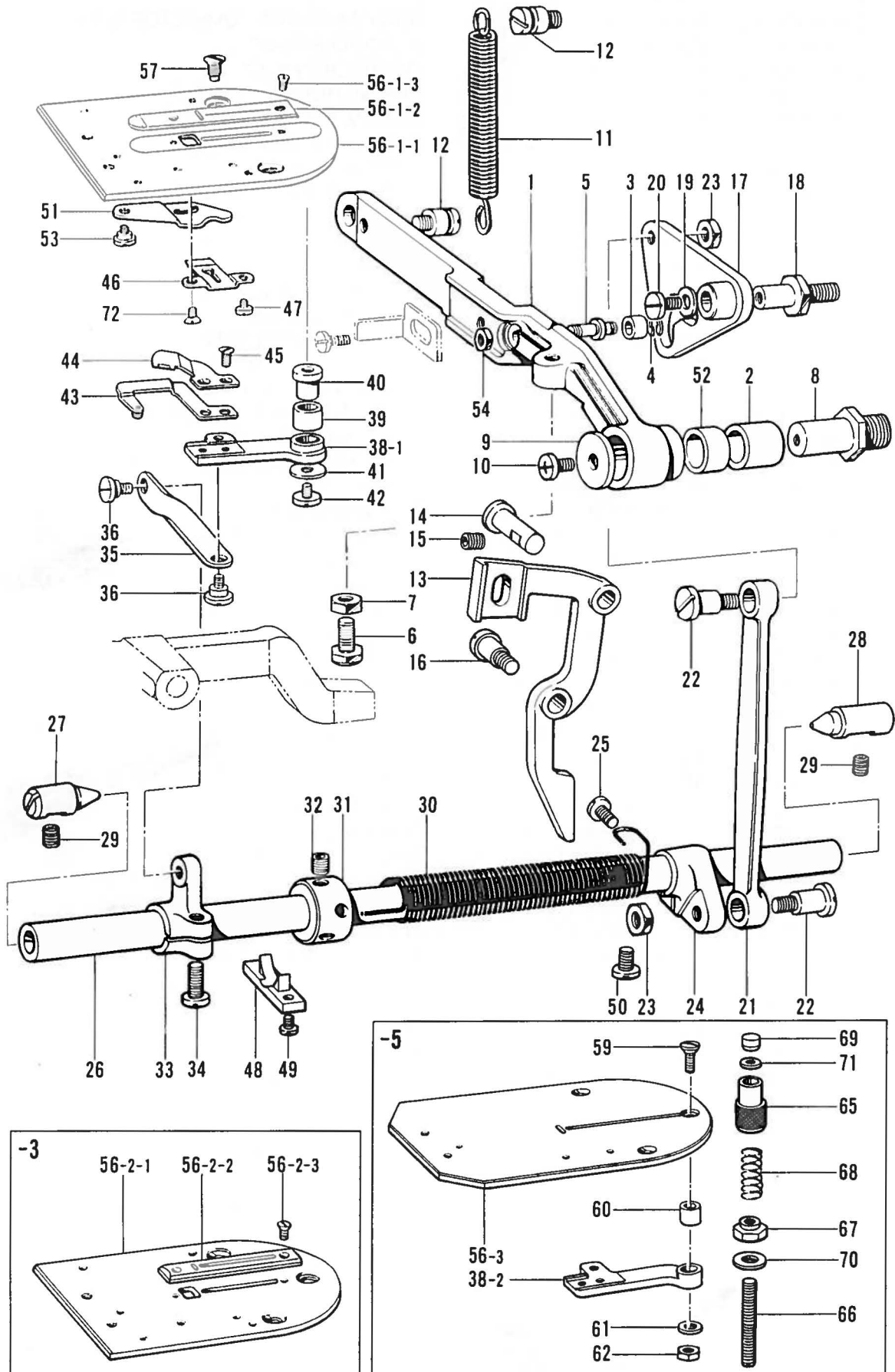

W. 下糸切り関係/Lower thread trimmer mechanism/Unterer Fadenabschneider/
 Mécanisme de la coupe-fil inférieur/Mecanismo de la recortadora de orillos inferior

REF.NO.	CODE	Q'TY	ヒンメイ	NAME OF PARTS	RM
2	142372000	1	DUブシユ	(DU) BUSH	
3	107744001	1	コロ	ROLLER	
4	048030342	1	トメワE3	RETAINING RING, E3	
5	141519001	1	イトキリサドウカムコロジク	ROLLER SHAFT	
8	141520001	1	シタイトキリレバージク	LOWER THREAD TRIMMER LEVER SHAFT	
9	149095001	1	ザガネ	WASHER	
10	062761012	1	ナベコ595-28X10	SCREW, PAN M5.95-28X10	
12	141472002	2	シタイトキリレバーバネカケ	SPRING HOOK	
13	141522001	1	シタイトキリレバーストツバ	LOWER THREAD TRIMMER LEVER STOPPER	
14	143788001	1	レバーストツバジク	STUD	
15	014760622	1	アナトメネジ5.95	SET SCREW, SOCKET (CP) M5.95	
16	115493002	1	ダンネジ5.95	STUD SCREW 5.95	
17	141523001	1	シタイトキリサドウカムクミ	LOWER THREAD TRIMMER DRIVING CAM ASSY	
18	141526001	1	シタイトキリサドウカムジク	LOWER THREAD TRIMMER DRIVING CAM STUD	
19	025050232	1	ヒラザガネチユウ-5	WASHER, PLAIN M 5	
20	106629002	1	シメネジ4.37	SCREW 4.37	
22	141528001	2	ダンネジ6.35	STUD SCREW 6.35	
23	150556001	2	ナツト6.35	NUT 6.35	
24	141529000	1	シタイトキリジクウデA	LOWER THREAD TRIMMER SHAFT ARM (A)	
25	062681212	1	ナベコ437-40X12	SCREW, PAN M4.37-40X12	
26	141530001	1	シタイトキリジク	LOWER THREAD TRIMMER SHAFT	
27	104847001	1	オクリジクセンタL	FEED SHAFT CENTER (L)	
28	104848001	1	オクリジクセンタR	FEED SHAFT CENTER (R)	
29	014760622	2	アナトメネジ5.95	SET SCREW, SOCKET (CP) M5.95	
30	141531001	1	シタイトキリジクバネ	SPRING	
31	141532001	1	セツトカラー	SET COLLAR	
32	014770622	2	アナトメネジ6.35クボミ	SET SCREW, SOCKET (CP) M6.35	
33	141533001	1	シタイトキリジクウデB	LOWER THREAD TRIMMER SHAFT ARM (B)	
34	062751612	1	ナベコ556-32X16	SCREW, PAN M5.56-32X16	
35	141534001	1	シタイトキリリンク	LOWER THREAD TRIMMER LINK	
36	141535001	2	ダンネジ4.76	STUD SCREW 4.76	
43	142416001	1	シタイトユルメレバークミ	LOWER THREAD RELEASE LEVER ASSY	
44	141541001	1	シタイトキリサドウハ	MOVABLE KNIFE	
45	141542001	2	サラネジ3.18	SCREW, FLAT M3.18	
46	141543001	1	シタイトキリコテイハ	FIXED KNIFE	
47	141544001	1	シメネジ3.18	SCREW 3.18	
48	141545001	1	シタイトキリジクシキリイタ	LOWER THREAD TRIMMER SHAFT PLATE	
49	062670612	2	ナベコ357-40X6	SCREW, PAN M3.57-40X6	
50	062761212	1	ナベコ595-28X12	SCREW, PAN M5.95-28X12	
51	142419001	1	シタイトユルメ	LOWER THREAD RELEASER	
52	142373000	1	DUブシユ	(DU) BUSH	
53	142420001	1	ダンネジ3.18	STUD SCREW 3.18	
54	110161004	1	ナツト4.76	NUT 4.76	
57	100032004	2	サラネジ4.37	SCREW, FLAT M4.37	
72	149288003	1	サラネジ3.18	SCREW, FLAT M3.18	

W. 下糸切り関係/Lower thread trimmer mechanism/Unterer Fadenabschneider/
 Mécanisme de la coupe-fil inférieur/Mecanismo de la recortadora de orillos inferior

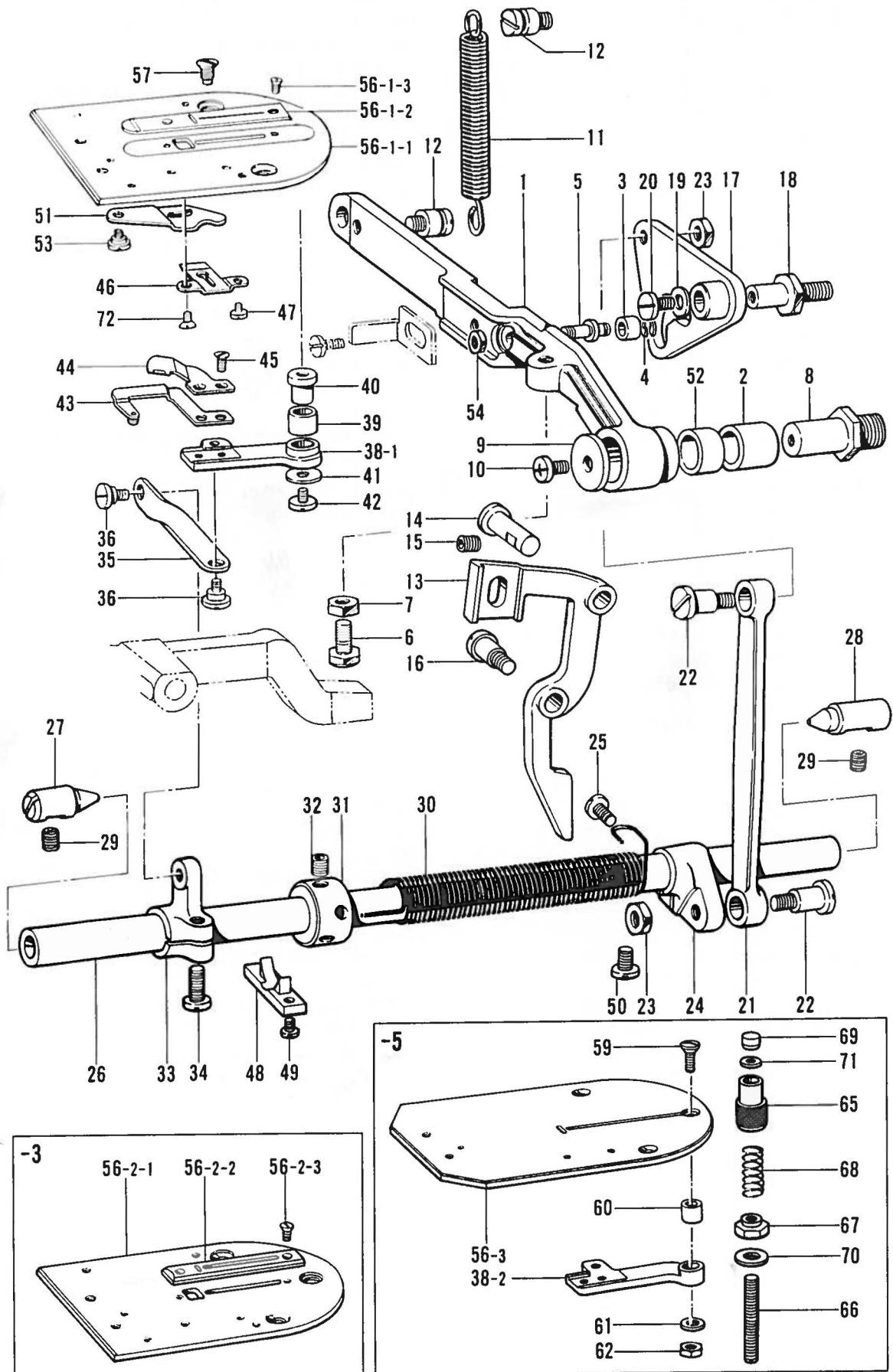

W. 下糸切り関係/Lower thread trimmer mechanism/Unterer Fadenabschneider/
Mécanisme de la coupe-fil inférieur/Mecanismo de la recortadora de orillos inferior

REF.NO.	CODE	Q'TY	ヒンメイ	NAME OF PARTS	RM
			<-2,-3,-5>		
1	141518009	1	シタイトキリレバー	LOWER THREAD TRIMMER LEVER	
6	115585001	1	ボルト7.94	BOLT, M7.94	
7	152997001	1	ナット7.94	NUT 7.94	
11	141521001	1	シタイトキリレバーヒキバネ	SPRING, EXTENSION	
21	141527001	1	シタイトキリサドウレンカン	LOWER THREAD TRIMMER DRIVING ROD	
			<-2,-3,-4>		
38-1	141537001	1	シタイトキリメストリツケウデ	LOWER THREAD TRIMMER SET ARM	
39	141538001	1	トリツケウデブシユA	BUSH (A)	
40	141539001	1	トリツケウデブシユB	BUSH (B)	
41	512769001	1	ザガネ	WASHER	
42	105451001	1	シメネジ3.57	SCREW 3.57	
			<-2,-4>		
56-1	145244001	1	ハリイタクミ	NEEDLE PLATE ASSY	
56-1-1	145245001	1	ベースハリイタU	BASE PLATE (U)	
56-1-2	145246001	1	ハリイタO	NEEDLE PLATE (O)	
56-1-3	145247001	2	サラネジ2.38	SCREW, FLAT M2.38	
			<-3>		
56-2	144633001	1	ハリイタ1.2クミ	NEEDLE PLATE 1.2 ASSY	
56-2-1	144634001	1	ベースハリイタ	BASE PLATE	
56-2-2	144635001	1	ハリイタ1.2	NEEDLE PLATE 1.2	
56-2-3	111073001	2	サラネジ2.38	SCREW, FLAT M2.38	
			<-5>		
38-2	147235001	1	シタイトキリメストリツケウデ	LOWER THREAD TRIMMER SET ARM	
56-3	147234001	1	ハリイタ50	NEEDLE PLATE 50	
59	105955002	1	シメネジ4.37	SCREW 4.37	
60	147236001	1	メストリツケウデコロ	KNIFE SET ARM ROLLER	
61	140025002	1	ザガネ	WASHER	
62	102571003	1	ナット4.37	NUT 4.37	
65	143394001	1	レバートメ	LEVER STOPPER	
66	140649001	1	トメネジ7.94	SET SCREW, M7.94	
67	140650001	1	チヨウセツナット	ADJUST NUT	
68	140651001	1	ストツバオシバネ	SPRING, COMPRESSION	
69	146011001	1	クツシヨン	CUSHION	
70	025080132	1	ヒラザガネシヨウ8	WASHER, PLAIN S 8	
71	111920000	1	ザガネ	WASHER	

X1. 付属装置関係(エア式ワンペダル装置)/Attachment set(Pneumatic one-pedal device)/
 Anbausatz(Pneumatische einpedalbedienung)/Jeu d'accessoires(Pedale unique
 pneumatique) / Juego de fijación(Unidad de un solo pedal neumatico)

エア関係 / Air pressure mechanism / Luftdruck / Mécanisme de la pression d'air /
 Mecanismo de la presión de air

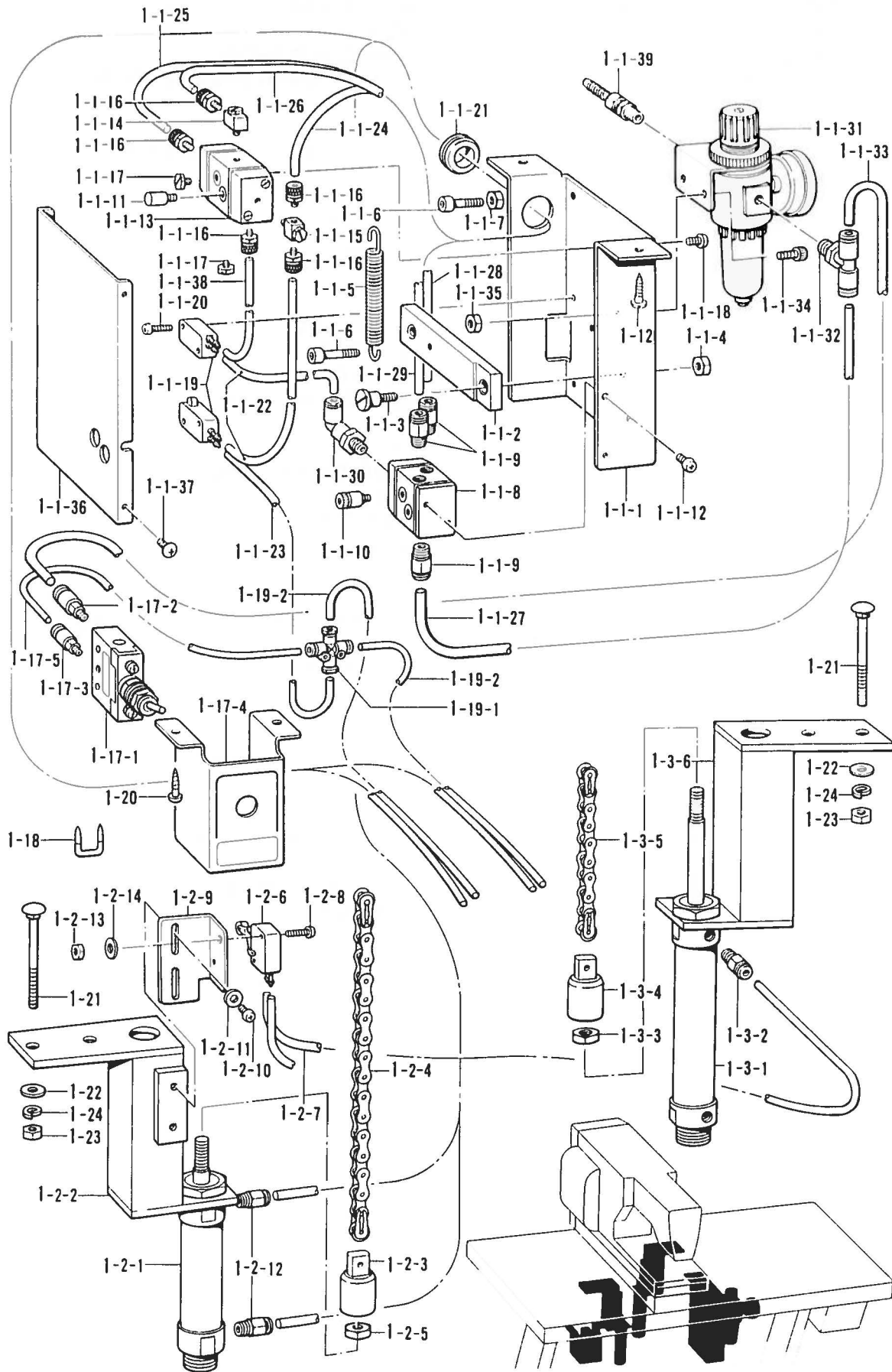

X1. 付属装置関係(エア一式ワンペダル装置)/Attachment set(Pneumatic one-pedal device) / Anbausatz(Pneumatische einpedalbedienung)/Jeu d'accessoires(Pedale unique pneumatique)/Juego de fijación(Unidad de un solo pedal neumatico)

REF.NO.	CODE	Q'TY	ヒンメイ	NAME OF PARTS	RM
1	S34196009	1	エアワンペダル	AIR TYPE ONE PEDAL DEVICE	
1-1	S01517109	1	スイッチボックス	SWITCH BOX ASSY	
1-1-1	S01518009	1	スイッチボックス	SWITCH BOX	
1-1-2	S01519001	1	スイッチレバー	SWITCH LEVER	
1-1-3	145486001	1	ダンネジ7.14	STUD SCREW 7.14	
1-1-4	100090004	1	ナット7.14	NUT 7.14	
1-1-5	S01520001	1	ヒキバネ	SPRING, EXTENSION	
1-1-6	018503022	2	アナボルト5X30	BOLT, SOCKET M5X30	
1-1-7	021500103	2	ナット1シユ5	NUT, 1 M5	
1-1-8	S01521000	1	エアオペレートバルブS	AIR OPERATE VALVE (S)	
1-1-9	S01522000	3	ハーフユニオン	HALF UNION	
1-1-10	153268001	2	シボリベン	THROTTLE VALVE	
1-1-11	153269001	1	サイレンサー	SILENCER	
1-1-12	002400803	2	+ナベコ4X8	SCREW, PAN M4X8	
1-1-13	S01523000	1	エアオペレートバルブW	AIR OPERATE VALVE (W)	
1-1-14	158658000	1	ユニバーサルエルボ	UNIVERSAL ELBOW	
1-1-15	S01524000	1	ユニバーサルチー	UNIVERSAL T-JOINT	
1-1-16	158660000	5	ナイロンホースニツブル	NIPPLE	
1-1-17	S01525000	2	プラグ	PLUG	
1-1-18	002400803	2	+ナベコ4X8	SCREW, PAN M4X8	
1-1-19	S01526000	2	マイクロメカバルブS	MICRO VALVE (S)	
1-1-20	002301603	4	+ナベコ3X16	SCREW, PAN M3X16	
1-1-21	S01527000	1	ゴムブツシユL	RUBBER BUSH (L)	
1-1-22	S01528000	2	エアチューブA (L=160)	AIR TUBE (A) (L=160)	
1-1-23	S01529100	1	エアチューブB (L=700)	AIR TUBE (B) (L=700)	
1-1-24	S01531000	1	エアチューブD (L=600)	AIR TUBE (D) (L=600)	
1-1-25	S01532000	1	エアチューブE (L=1700)	AIR TUBE (E) (L=1700)	
1-1-26	S01533000	1	エアチューブF (L=1700)	AIR TUBE (F) (L=1700)	
1-1-27	S01534000	1	エアチューブG (L=200)	AIR TUBE (G) (L=200)	
1-1-28	S01535000	1	エアチューブH (L=600)	AIR TUBE (H) (L=600)	
1-1-29	S01536000	1	エアチューブI (L=600)	AIR TUBE (I) (L=600)	
1-1-30	S04909000	1	エルボユニオン	ELBOW UNION	
1-1-31	S01540000	1	レギュレータ	REGULATOR	
1-1-32	S24514000	1	チーユニオン	T-JOINT	
1-1-33	S24518000	1	エアホース0604N120W(L=1200)	AIR TUBE 0604N120W (L=1200)	
1-1-34	018061222	2	アナボルト6X12	BOLT, SOCKET M6X12	
1-1-35	021060206	2	2シユナット6	NUT, 2 M6	
1-1-36	S01543009	1	スイッチカバー	SWITCH COVER	
1-1-37	002400803	4	+ナベコ4X8	SCREW, PAN M4X8	
1-1-38	S01539000	1	エアチューブK (L=45)	AIR TUBE (K) (L=45)	
1-1-39	140678001	1	ホースツギテ	HOSE JOINT	
1-2	S29858009	1	オサエシリンダ4クミ	PRESSER CYLINDER 4 ASSY	
1-2-1	S31804000	1	エアシリンダ25-50A	AIR CYLINDER 25-50A	
1-2-2	S31803009	1	シリンダブラケットP	CYLINDER BRACKET (P)	
1-2-3	S01547001	1	ツギテ	JOINT	
1-2-4	S01574000	1	17Pチェーン	17P CHAIN	
1-2-5	149488001	1	ロッドナット	ROD NUT	
1-2-6	S01548000	1	マイクロメカバルブSR	MICRO VALVE (SR)	
1-2-7	S01537000	1	エアチューブJ (L=500)	AIR TUBE (J) (L=500)	
1-2-8	002301603	2	+ナベコ3X16	SCREW, PAN M3X16	
1-2-9	S24575001	1	スイッチプレート	SWITCH PLATE	
1-2-10	002400803	2	+ナベコ4X8	SCREW, PAN M4X8	
1-2-11	025040233	2	ヒラザガネチユウ4	WASHER, PLAIN M 4	
1-2-12	S01522000	2	ハーフユニオン	HALF UNION	
1-2-13	021300103	1	ナット1シユ3	NUT, 1 M3	
1-2-14	025030335	1	ヒラザガネダイ3	WASHER, PLAIN L 3	

X1. 付属装置関係(エア式ワンペダル装置)/Attachment set(Pneumatic one-pedal device) / Anbausatz(Pneumatische einpedalbedienung)/Jeu d'accessoires(Pedale unique pneumatique)/Juego de fijación(Unidad de un solo pedal neumático)

エア関係 / Air pressure mechanism / Luftdruck / Mécanisme de la pression d'air / Mecanismo de la presión de air

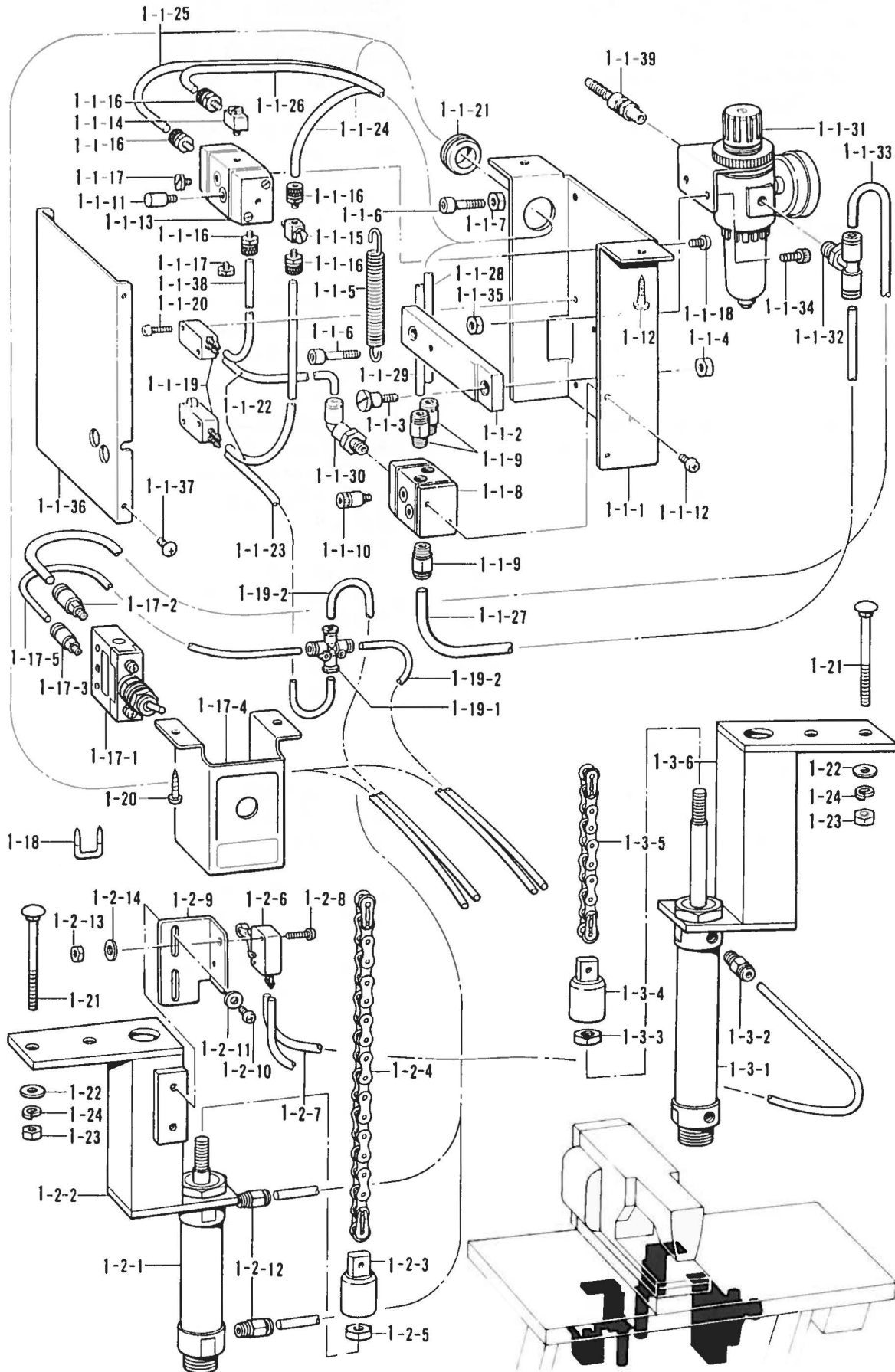

X1. 付属装置関係(エア-式ワンペダル装置)/Attachment set(Pneumatic one-pedal device) /
 Anbausatz(Pneumatische einpedalbedienung)/Jeu d'accessoires(Pedale unique
 pneumatique)/Juego de fijación(Unidad de un solo pedal neumatico)

REF.NO.	CODE	Q'TY	ヒンメイ	NAME OF PARTS	RM
1-3	S29859009	1	シドウシリンダクミ	STARTING CYLINDER ASSY	
1-3-1	S01551000	1	エア-シリンダ25-50T	AIR CYLINDER 25-50T	
1-3-2	S04910000	1	ハーフユニオン	HALF UNION	
1-3-3	149488001	1	ロツドナツト	ROD NUT	
1-3-4	S01547001	1	ツギテ	JOINT	
1-3-5	S00780000	1	9Pチェーン	9P-CHAIN	
1-3-6	S29860009	1	シリンダブラケットS	CYLINDER BRACKET (S)	
1-12	031553202	2	マルモクネジ5.5X32	WOOD SCREW, ROUND M5.5X32	
1-17	S24515000	1	エア-ワンペソウチSWクミ	AIR TYPE ONE PEDAL DEVICE SWITCH ASSY	
1-17-1	S24516000	1	メカニカルバルブ	MECHANICAL VALVE	
1-17-2	S14145000	1	ハーフユニオン06-M5	HALF UNION 06-M5	
1-17-3	S04905000	1	ハーフユニオン	HALF UNION	
1-17-4	S24517000	1	エア-ソウチSWパネル	AIR DEVICE SWITCH PANEL	
1-17-5	S01530000	1	エア-チューブC (L=1700)	AIR TUBE (C) (L=1700)	
1-18	200190001	5	ステツブル	STAPLE	
1-19	S24519000	1	ジユウジツギテクミ	CROSS JOINT ASSY	
1-19-1	S24520000	1	ジユウジツギテ04-Q	CROSS JOINT 04-Q	
1-19-2	S01530000	2	エア-チューブC (L=1700)	AIR TUBE (C) (L=1700)	
1-20	101118001	2	マルモクネジ4.5X20	WOOD SCREW, ROUND M4.5X20	
1-21	119755001	4	カクネボルト6X60	BOLT, M6X60	
1-22	025060336	4	ヒラザガネダイ6	WASHER, PLAIN L 6	
1-23	021060106	4	ナツト1シユ6	NUT, 1 M6	
1-24	028060242	4	バネザガネ2-6	WASHER, SPRING 2-6	

118-817-940

X2. 付属装置関係(エア一式ワンペダル装置)/Attachment set(Pneumatic one-pedal device) / Anbausatz(Pneumatische einpedalbedienung)/Jeu d'accessoires(Pedale unique pneumatique)/Juego de fijación(Unidad de un solo pedal neumatico)

OP頭部組付関係 / Single pedal mechanism installed in the head / Maschineerteil mit einem pedal / Mécanisme de l'ensemble de la tête pour une machine avec une seule pédale / Mecanismo del conjunto de cabeza con pedal sencillo

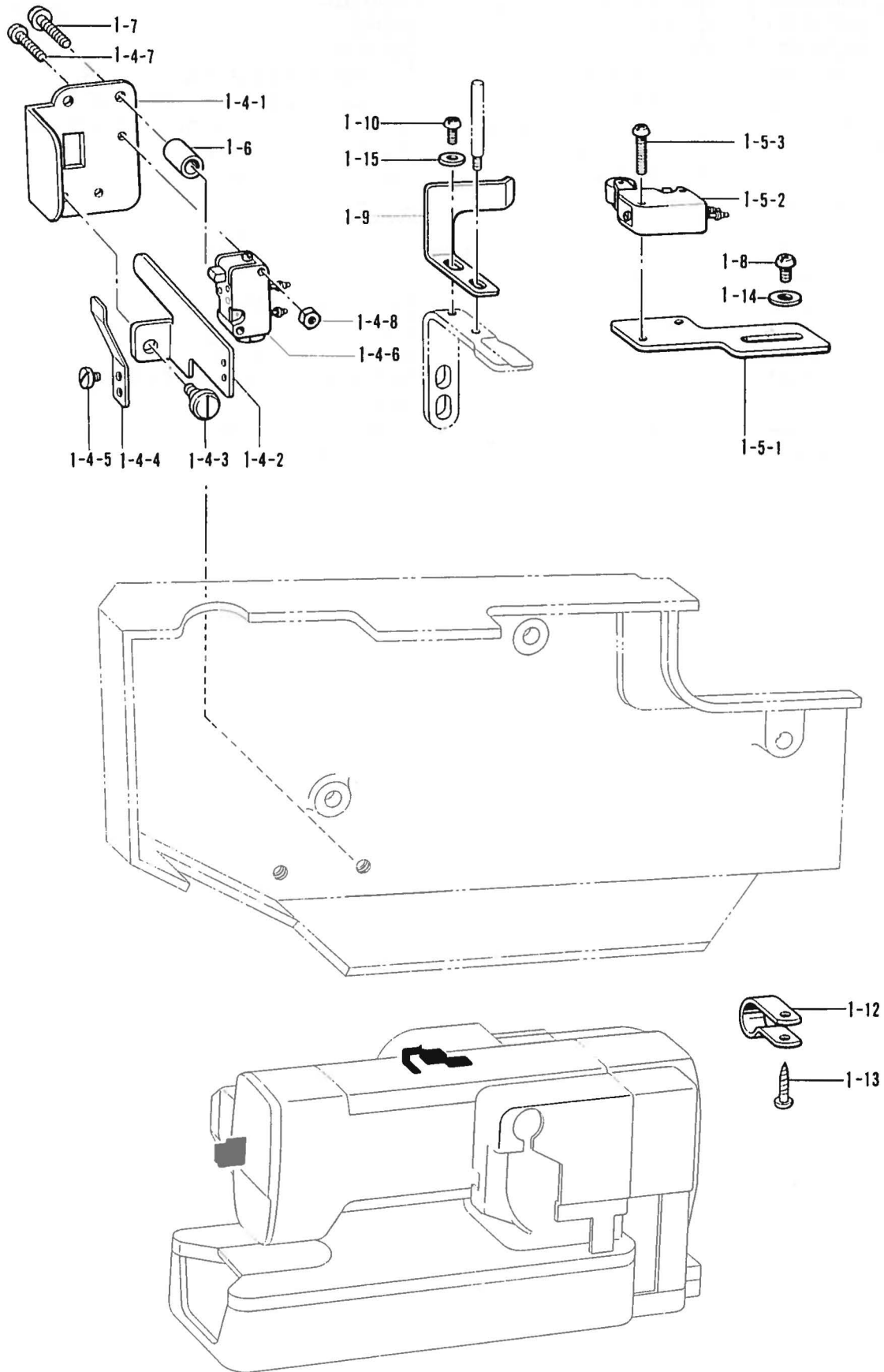

X2. 付属装置関係(エア一式ワンペダル装置)/Attachment set(Pneumatic one-pedal device) / Anbausatz(Pneumatische einpedalbedienung)/Jeu d'accessoires(Pedale unique pneumatique)/Juego de fijación(Unidad de un solo pedal neumatico)

REF.NO.	CODE	Q'TY	ヒンメイ	NAME OF PARTS	RM
1-4	S33014009	1	センサーSW7クミ	SENSOR SWITCH 7 ASSY	
1-4-1	S33011009	1	センサーベース7	SENSOR BASE 7	
1-4-2	S33012001	1	リセットレバー	RESET LEVER	
1-4-3	113730001	1	ダンネジ4.37	STUD SCREW 4.37	
1-4-4	S01577001	1	スイッチバネ4	SPRING, PLATE 4	
1-4-5	110215002	2	シメネジ3.57	SCREW 3.57	
1-4-6	S01557000	1	マイクロメカバルブD	MICRO VALVE (D)	
1-4-7	002301603	2	+ナベコ3X16	SCREW, PAN M3X16	
1-4-8	021300103	2	ナット1シユ3	NUT, 1 M3	
1-5	S01580001	1	ゲンテンSWクミ	HOME POSITION SWITCH ASSY	
1-5-1	S01581001	1	ゲンテンイタ	HOME POSITION PLATE	
1-5-2	S01548000	1	マイクロメカバルブSR	MICRO VALVE (SR)	
1-5-3	062301405	2	ナベコ3X14	SCREW, PAN M3X14	
1-6	S01578001	2	カラーA	COLLAR (A)	
1-7	062681612	2	ナベコ437-40X16	SCREW, PAN M4.37-40X16	
1-8	062670612	2	ナベコ357-40X6	SCREW, PAN M3.57-40X6	
1-9	S01582001	1	ドグ	DOG	
1-10	062680712	1	ナベコ437-40X7	SCREW, PAN M4.37-40X7	
1-12	525664000	2	コードホルダ#6	CORD HOLDER (6N)	
1-13	031411304	2	マルモクネジ4.1X13	WOOD SCREW, ROUND M4.1X13	
1-14	105161003	2	ザガネ	WASHER	
1-15	100645003	1	ザガネ	WASHER	

Y. 特別注文部品/Option parts/Sonderzubehör/
 Pièces en option/Piezas opcionales

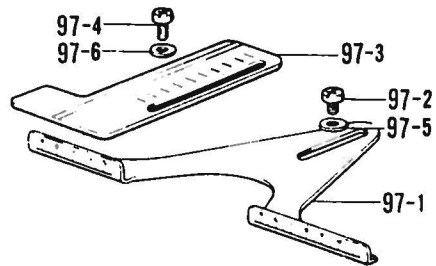
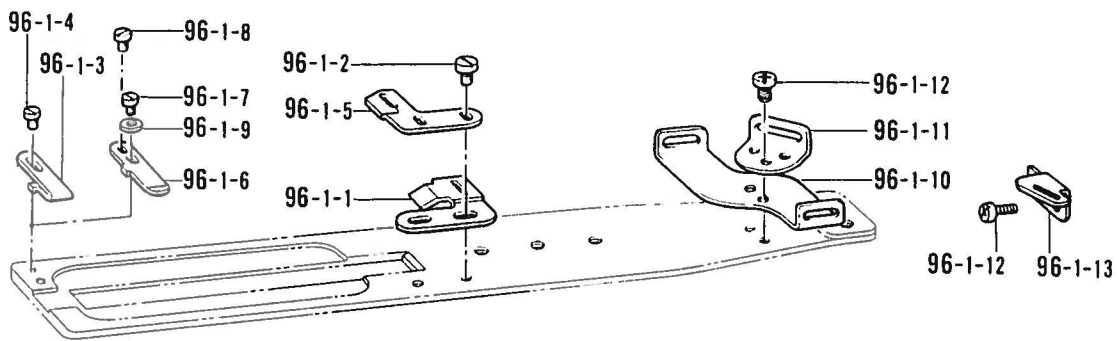
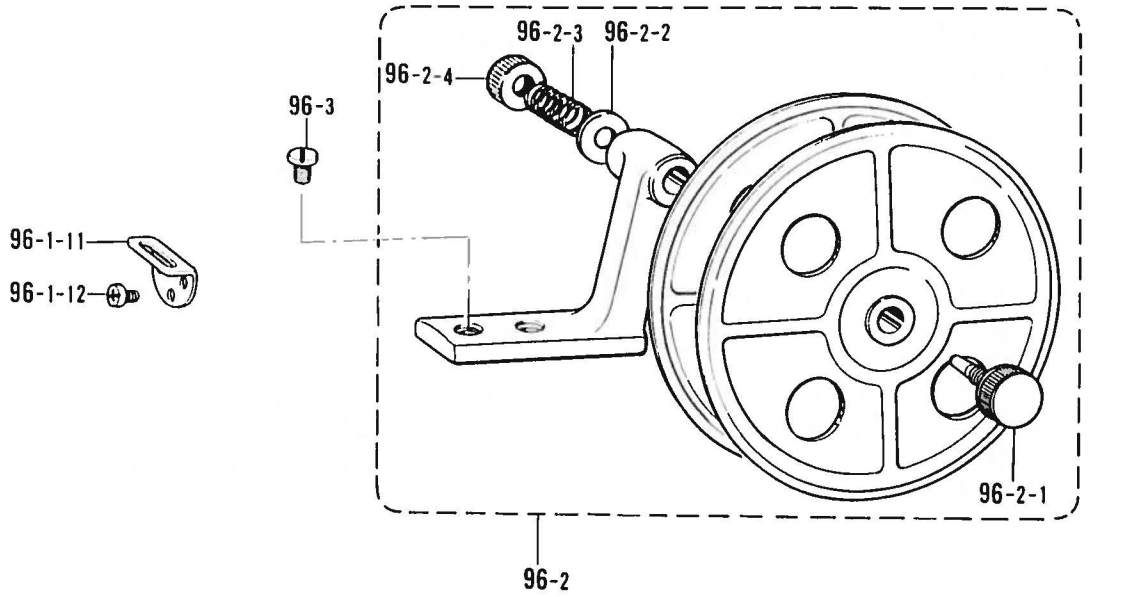

Y. 特別注文部品/Option parts/Sonderzubehör/
Pièces en option/Piezas opcionales

REF.NO.	CODE	Q'TY	ヒンメイ	NAME OF PARTS	RM
96	S25672009	1	テープオサエワインダークミ	TAPE GUARD WINDER ASSY	
96-1	S25671001	1	テープオサエクミ	TAPE GUARD ASSY	
96-1-1	144998001	1	テープオサエB	TAPE GUARD (B)	
96-1-2	105288002	2	シメネジ2.38	SCREW 2.38	
96-1-3	144997001	1	テープオサエA	TAPE GUARD (A)	
96-1-4	122771002	2	シメネジ2.38	SCREW 2.38	
96-1-5	144999001	1	テープオサエC	TAPE GUIDE (C)	
96-1-6	144628001	1	テープオサエF	TAPE GUARD (F)	
96-1-7	122771002	1	シメネジ2.38	SCREW 2.38	
96-1-8	105970001	1	シメネジ2.38	SCREW 2.38	
96-1-9	110067001	1	カラー	COLLAR	
96-1-10	143749001	1	テープアンナイシタ	TAPE GUIDE (LOWER)	
96-1-11	143748001	2	テープアンナイウエ	TAPE GUIDE (UPPER)	
96-1-12	062660412	6	ナベコ318-40X4	SCREW, PAN M3.18-40X4	
96-1-13	145441001	1	テープアンナイ	TAPE GUIDE	
96-2	143767009	1	テープワインダーダイクミ	TAPE WINDER BRACKET ASSY	
96-2-1	143980001	1	ツマミネジ	SCREW	
96-2-2	108494001	1	ザガネ	WASHER	
96-2-3	108495001	1	テープワインダオシバネ	SPRING, COMPRESSION	
96-2-4	100136001	1	イトチヨウシナツト	TENSION NUT	
96-3	107407003	2	シメネジ4.37	SCREW 4.37	
97	S31893001	1	ジヨウギクミ	RULLER ASSY	
97-1	141705001	1	ヨコジヨウギ	RULLER	
97-2	062680512	2	ナベコ437-40X5	SCREW, PAN M4.37-40X5	
97-3	147156001	1	タテジヨウギ	RULLER	
97-4	062680512	2	ナベコ437-40X5	SCREW, PAN M4.37-40X5	
97-5	116662003	2	ザガネ	WASHER	
97-6	025680232	2	ヒラザガネチユウ4.37	WASHER, PLAIN M 4.37	

◎ 付属品の明細は変更することがあります。

◎ The details of included accessories are subject to change.

◎ Änderungen in der Aufstellung der Mitgelieferten Zubehöre sind vorbehalten.

◎ Les détails des accessoires inclus sont sujets à des changements.

◎ Los detalles de los accesorios incluidos pueden variar.

118-817-910

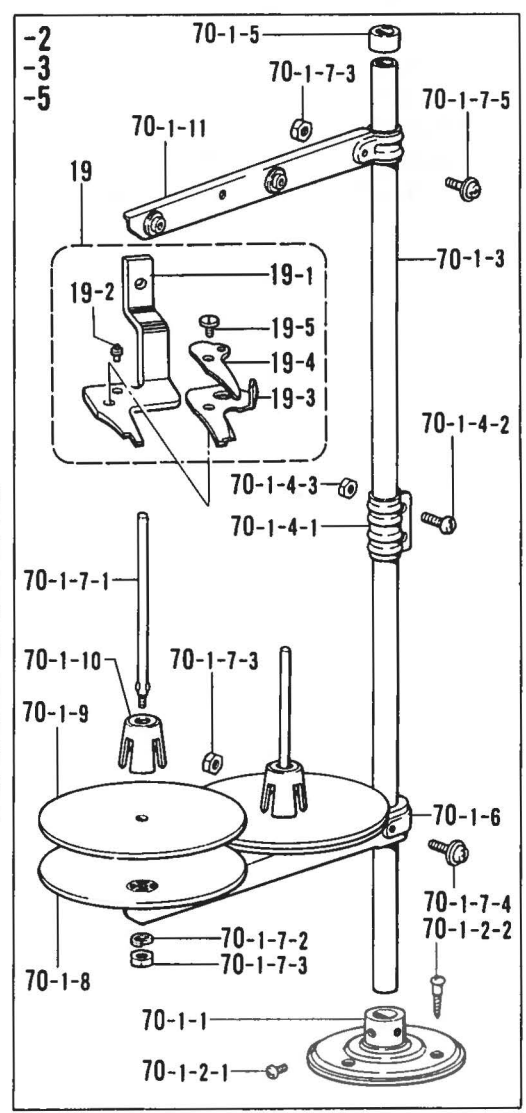
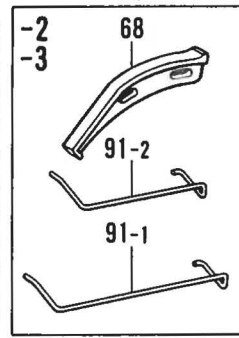
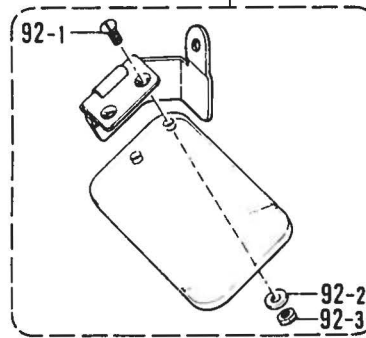
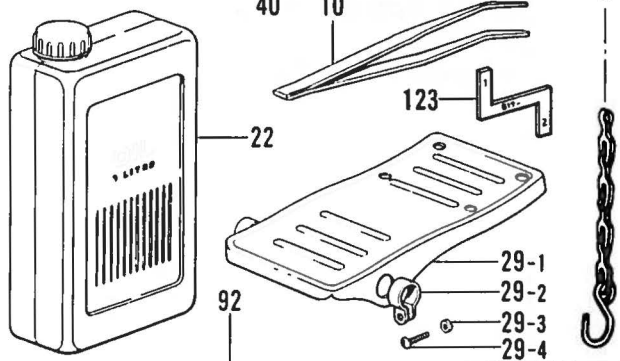
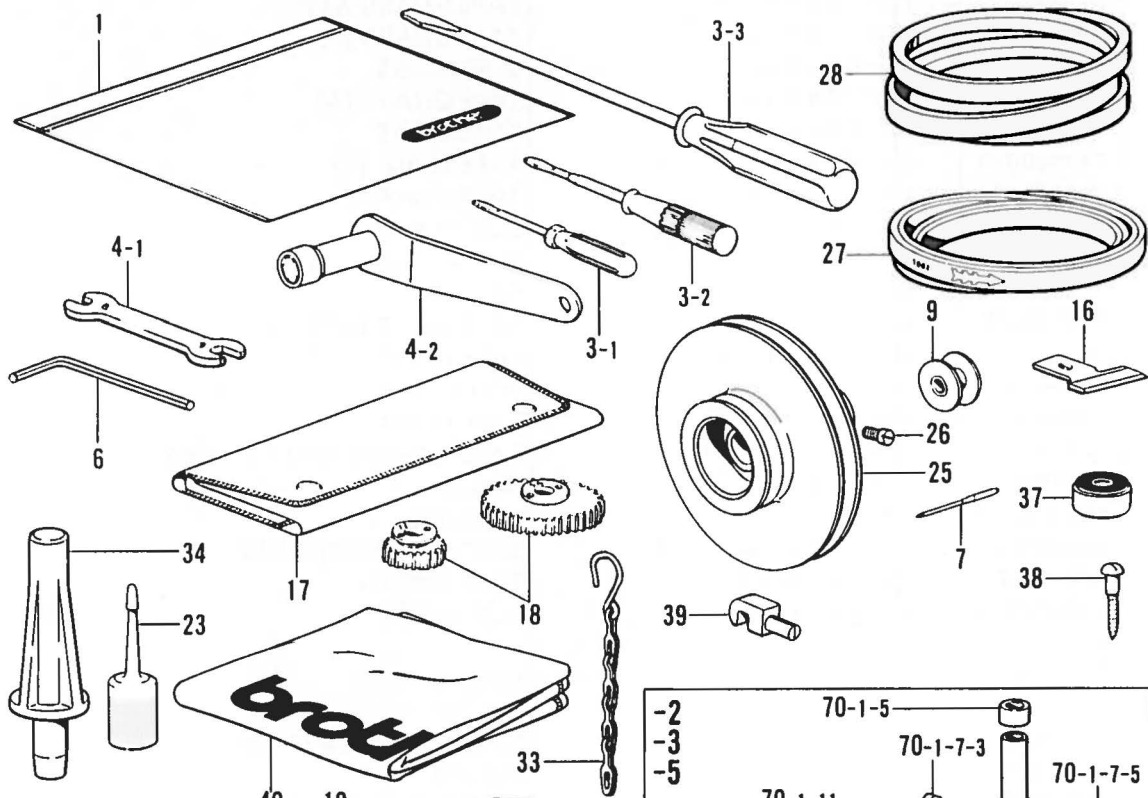

Z1. 付属品関係/Accessories/Zubehör/Accessoires/Accesorios

REF.NO.	CODE	Q'TY	ヒンメイ	NAME OF PARTS	RM
1	122991001	1	フゾクヒンポリフクロ	ACCESSORY BAG	
3-1	142443001	1	ネジマワシ1.9X52	SCREW DRIVER 1.9X52	
3-2	118837001	1	ネジマワシ3.4X70	SCREW DRIVER 3.4X70	
3-3	101572101	1	ネジマワシ5.5X190	SCREW DRIVER 5.5X190	
4-1	100887001	1	スパナ8X9	SPANNER 8X9	
4-2	143949001	1	ボツクススパナ12	BOX SPANNER 12	
6	142721001	1	6カクボウスパナ3	HEXAGONAL WRENCH 3	
7	※	4	ミシンハリDPX5	NEEDLE DPX5	
9	146025001	3	ボビン	BOBBIN	
10	117466000	1	ピンセット	PINCETTE	
16	※	1	カッタ	CUTTER	
17	142745002	1	チエンジギヤケース	CHANGE GEAR CASE	
18	※	※	チエンジギヤ	CHANGE GEAR	
22	154702001	1	オイルタンク	OIL TANK	
23	506701000	1	ポリオイラークミ	POLY OILER ASSY	
25	※	1	モータプーリ	MOTOR PULLEY	
26	105073001	2	アタマツキトメネジ5.95	SET SCREW 5.95	
27	141711100	1	ヒラベルト	BELT	
28	※	※	VベルトMシロ	BELT, VM WHITE	
29	116185209	2	ペタルクミ	PEDAL ASSY	
29-1	117437109	2	オサエアゲフミイタ	FOOT PEDAL	
29-2	116016001	4	ペタルトメ	PEDAL STOPPER	
29-3	021400106	4	1シユナツト4	NUT, 1 M4	
29-4	062401416	4	ナベコ4X14	SCREW, PAN M4X14	
33	149247001	2	クサリクミ	CHAIN ASSY	
34	516080009	1	トウブササエマクラ	HEAD REST	
37	146254001	4	モータカンザ	COLLAR	
38	101125000	4	マルモクネジ6.2X32	WOOD SCREW, ROUND M6.2X32	
39	141256001	2	トウブヒンジ	HEAD HINGE	
40	144226001	1	-----	HEAD COVER	
92	143971001	1	-----	PLASTIC EYE GUARD ASSY	
92-1	501700001	2	-----	SCREW, FLAT M3.18X7	
92-2	025030232	2	-----	WASHER, PLAIN M 3	
92-3	021660102	2	-----	NUT, 1 M3.18	
68	142734001	1	<-2,-3> テイシカムヘンAS	STOP CAM SEGMENT (AS)	
91-1	150561000	1	-----	FINGER GUARD (S)	
91-2	150563000	1	-----	FINGER GUARD (L)	
123	S32993001	1	<-2> デアイゲージ817-2	GAUGE 817-2	
123	S32994001	1	<-3> デアイゲージ817-3	GAUGE 817-3	
123	S32995001	1	<-4> デアイゲージ817-4	GAUGE 817-4	
123	S32996001	1	<-5> デアイゲージ817-5	GAUGE 817-5	

◎ 付属品の明細は変更することがあります。

◎ The details of included accessories are subject to change.

◎ Änderungen in der Aufstellung der Mitgelieferten Zubehöre sind vorbehalten.

◎ Les détails des accessoires inclus sont sujets à des changements.

◎ Los detalles de los accesorios incluidos pueden variar.

Z1. 付屬品關係/Accessories/Zubehör/Accessoires/Accesorios

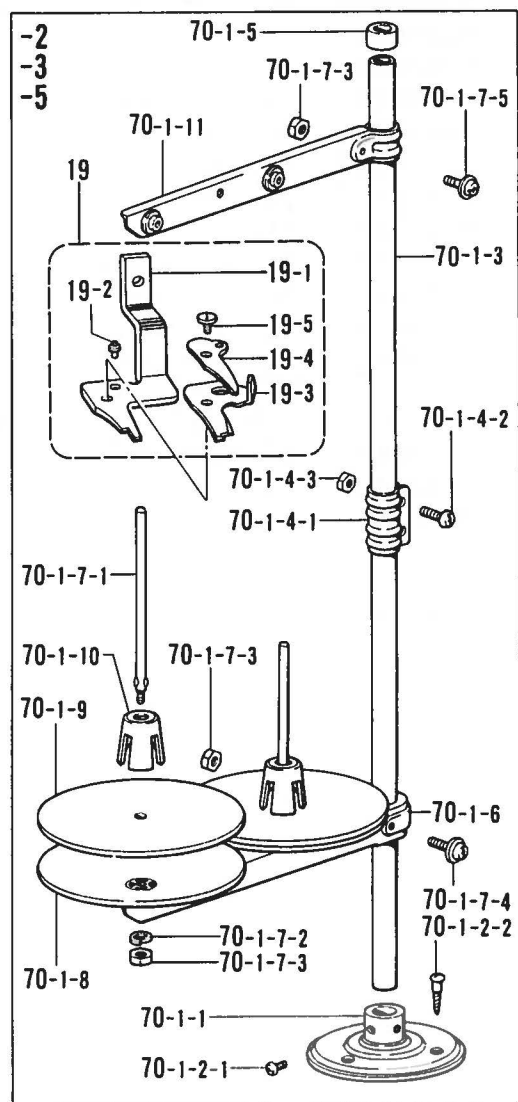
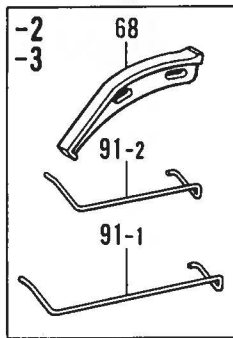
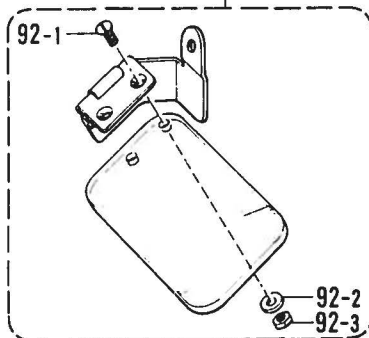
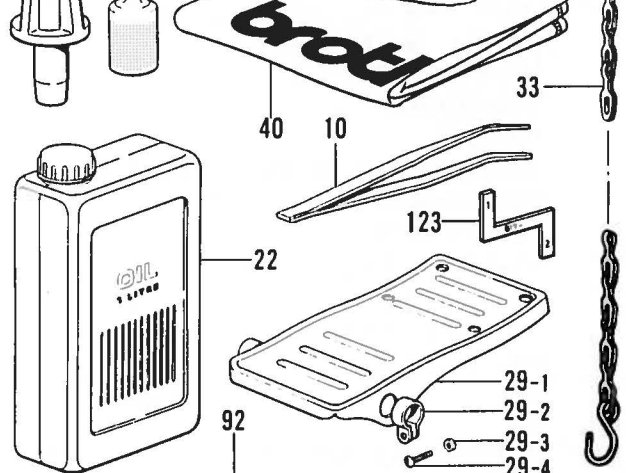
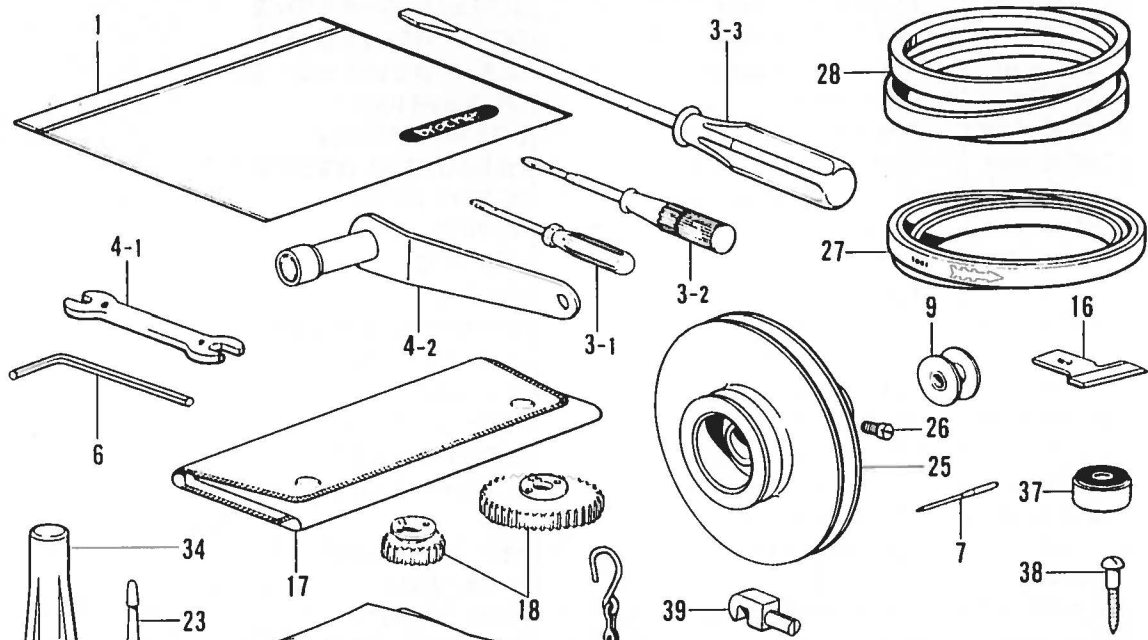

Z1. 付属品関係/Accessories/Zubehör/Accessoires/Accesorios

REF.NO.	CODE	Q'TY	ヒンメイ	NAME OF PARTS	RM
<-2,-3,-5>					
19	141509101	1	ハサミクミ	UPPER THREAD TRIMMER ASSY	
19-1	141510101	1	ハサミD	UPPER THREAD TRIMMER (D)	
19-2	141511000	1	ハサミUストツバピン	PIN	
19-3	141512101	1	ハサミM	UPPER THREAD TRIMMER (M)	
19-4	141513001	1	ハサミウエ	UPPER THREAD TRIMMER (UPPER)	
19-5	141514001	1	ハサミダンネジ	STUD SCREW	
70-1	S02761109	1	イトタテダイクミ2	COTTON STAND ASSY (2)	
70-1-1	150189109	1	ブラケット	BRACKET	
70-1-2	S02773001	1	ブラケットネジセット	COTTON STAND BRACKET SCREW SET	
70-1-2-1	062060806	2	ナベコ6X8	SCREW, PAN M6X8	
70-1-2-2	031452206	3	マルモク45X22	WOOD SCREW, ROUND M4.5X22	
70-1-3	150172003	2	コラムパイプ	COLUMN PIPE	
70-1-4	150106003	1	コラムジョイントクミ	COLUMN JOINT ASSY	
70-1-4-1	150173003	1	コラムジョイント	COLUMN JOINT	
70-1-4-2	062501406	2	ナベコ5X14	SCREW, PAN M5X14	
70-1-4-3	021500106	2	1シユナツト5	NUT, 1 M5	
70-1-5	150174000	1	コラムキャップ	COLUMN CAP	
70-1-6	S02778002	1	スプールホルダー2	SPOOL HOLDER 2	
70-1-7	S02780001	1	スプールネジセット2	SPOOL SCREW SET 2	
70-1-7-1	150179002	2	スプールジクB	SPOOL SHAFT (B)	
70-1-7-2	028050246	2	バネザガネ2-5	WASHER, SPRING 2-5	
70-1-7-3	021500106	4	1シユナツト5	NUT, 1 M5	
70-1-7-4	050503006	1	ナベコヒラザ5X30	SCREW, PAN (P WASHER) M5X30	
70-1-7-5	050501406	1	ナベコヒラザ5X14	SCREW, PAN (P WASHER) M5X14	
70-1-8	150180001	2	ウケザラ	SPOOL STAND BASE	
70-1-9	150182000	2	スプールマット	SPOOL MAT	
70-1-10	126863001	2	スプールのクッション	SPOOL CUSHION	
70-1-11	S02786002	1	スレツドハンガークミ2	THREAD HANGER ASSY 2	

◎ 付属品の明細は変更することがあります。

◎ The details of included accessories are subject to change.

◎ Änderungen in der Aufstellung der Mitgelieferten Zubehöre sind vorbehalten.

◎ Les détails des accessoires inclus sont sujets à des changements.

◎ Los detalles de los accesorios incluidos pueden variar.

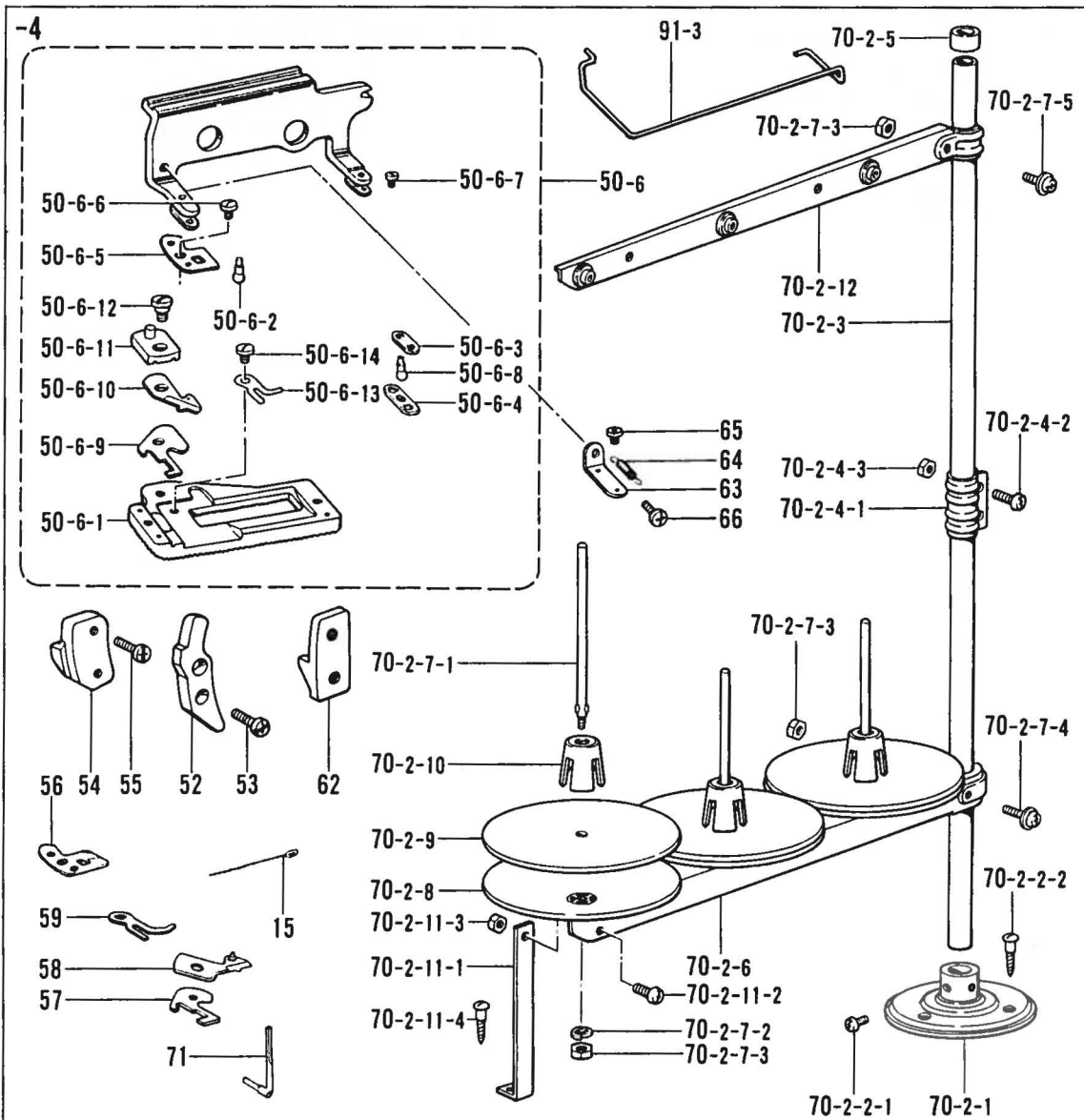
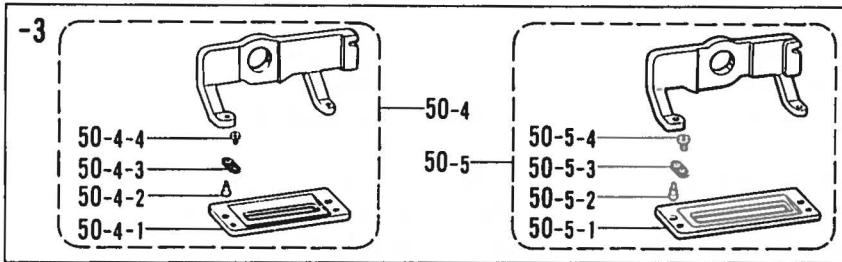
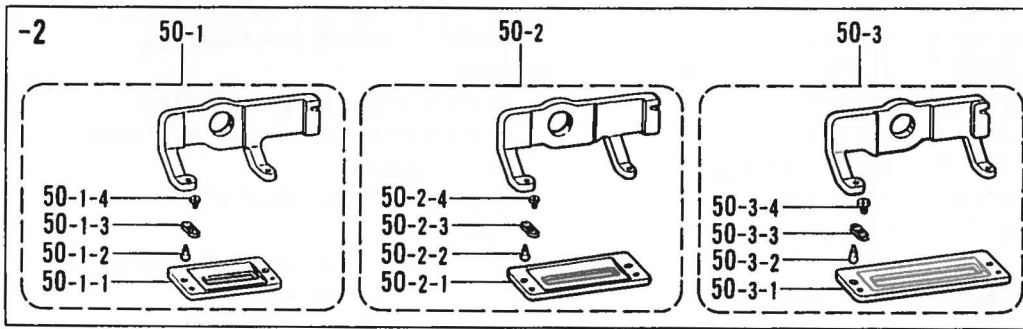

Z2 . 付属品関係/Accessories/Zubehör/Accessoires/Accesorios

REF.NO.	CODE	Q'TY	ヒンメイ	NAME OF PARTS	RM
<フィンガーガード用 / For finger guard >					
<-2>					
50-1	150763001	1	ヌノツカミ16クミ	UPPER CLAMPING FOOT ASSY (16MM)	
50-1-1	145146001	1	ヌノツカミS	UPPER CLAMPING FOOT (S)	
50-1-2	144496001	2	ヌノツカミササエピン	PIN	
50-1-3	107401001	2	ヌノツカミササエイタバネ	SPRING,PLATE	
50-1-4	107404001	2	シメネジ1.98	SCREW 1.98	

50-2	150764001	1	-----	UPPER CLAMPING FOOT ASSY (25MM)	
50-2-1	144498001	1	-----	UPPER CLAMPING FOOT RUBBER	
50-2-2	144496001	2	-----	PIN	
50-2-3	107401001	2	-----	SPRING,PLATE	
50-2-4	107404001	2	-----	SCREW 1.98	

50-3	150765001	1	-----	UPPER CLAMPING FOOT ASSY (32MM)	
50-3-1	144575001	1	-----	UPPER CLAMPING FOOT (32MM)	
50-3-2	144496001	2	-----	PIN	
50-3-3	107401001	2	-----	SPRING,PLATE	
50-3-4	107404001	2	-----	SCREW 1.98	

<-3>					
50-4	150767001	1	ニットヨウヌノツカミ16クミ	UPPER CLAMPING FOOT ASSY (16MM-3)	
50-4-1	145136001	1	ニットヨウヌノツカミS	UPPER CLAMPING FOOT (S)	
50-4-2	144496001	2	ヌノツカミササエピン	PIN	
50-4-3	144707001	2	ヌノツカミササエイタバネ	SPRING,PLATE	
50-4-4	107404001	2	シメネジ1.98	SCREW 1.98	

50-5	150769001	1	-----	UPPER CLAMPING FOOT ASSY (32MM-3)	
50-5-1	144632001	1	-----	UPPER CLAMPING FOOT (L)	
50-5-2	144496001	2	-----	PIN	
50-5-3	144707001	2	-----	SPRING,PLATE	
50-5-4	107404001	2	-----	SCREW 1.98	

<-4>					
50-6	150771001	1	ヌノツカミ(32-4)クミ	UPPER CLAMPING FOOT ASSY (32-4)	
50-6-1	145375001	1	ヌノツカミ(32-4)	UPPER CLAMPING FOOT (32-4)	
50-6-2	144496001	1	ヌノツカミササエピン	PIN	
50-6-3	107401001	1	ヌノツカミササエイタバネ	SPRING,PLATE	
50-6-4	145365001	1	ヌノツカミイタバネ	SPRING,PLATE	
50-6-5	145366001	1	イトオサエ	THREAD PRESSER	
50-6-6	111105001	2	シメネジ2.38	SCREW 2.38	
50-6-7	107404001	1	シメネジ1.98	SCREW 1.98	
50-6-8	146034001	1	ヌノツカミササエピン	PIN	
50-6-9	145367001	1	ヒモキリコティバ	GIMP TRIMMING FIXED KNIFE	
50-6-10	145731001	1	ヒモキリイドウハクミ	GIMP TRIMMING MOVABLE KNIFE ASSY	
50-6-11	145369001	1	ヒモキリクランク	GIMP TRIMMING CRANK	
50-6-12	145370001	1	ダンネジ3.57	STUD SCREW 3.57	
50-6-13	145373001	1	ヒモヨセレバ	GIMP DETACH LEVER	
50-6-14	145371001	1	ダンネジ2.38	STUD SCREW 2.38	

◎ 付属品の明細は変更することがあります。
 ◎ The details of included accessories are subject to change.
 ◎ Änderungen in der Aufstellung der Mitgelieferten Zubehöre sind vorbehalten.
 ◎ Les détails des accessoires inclus sont sujets à des changements.
 ◎ Los detalles de los accesorios incluidos pueden variar.

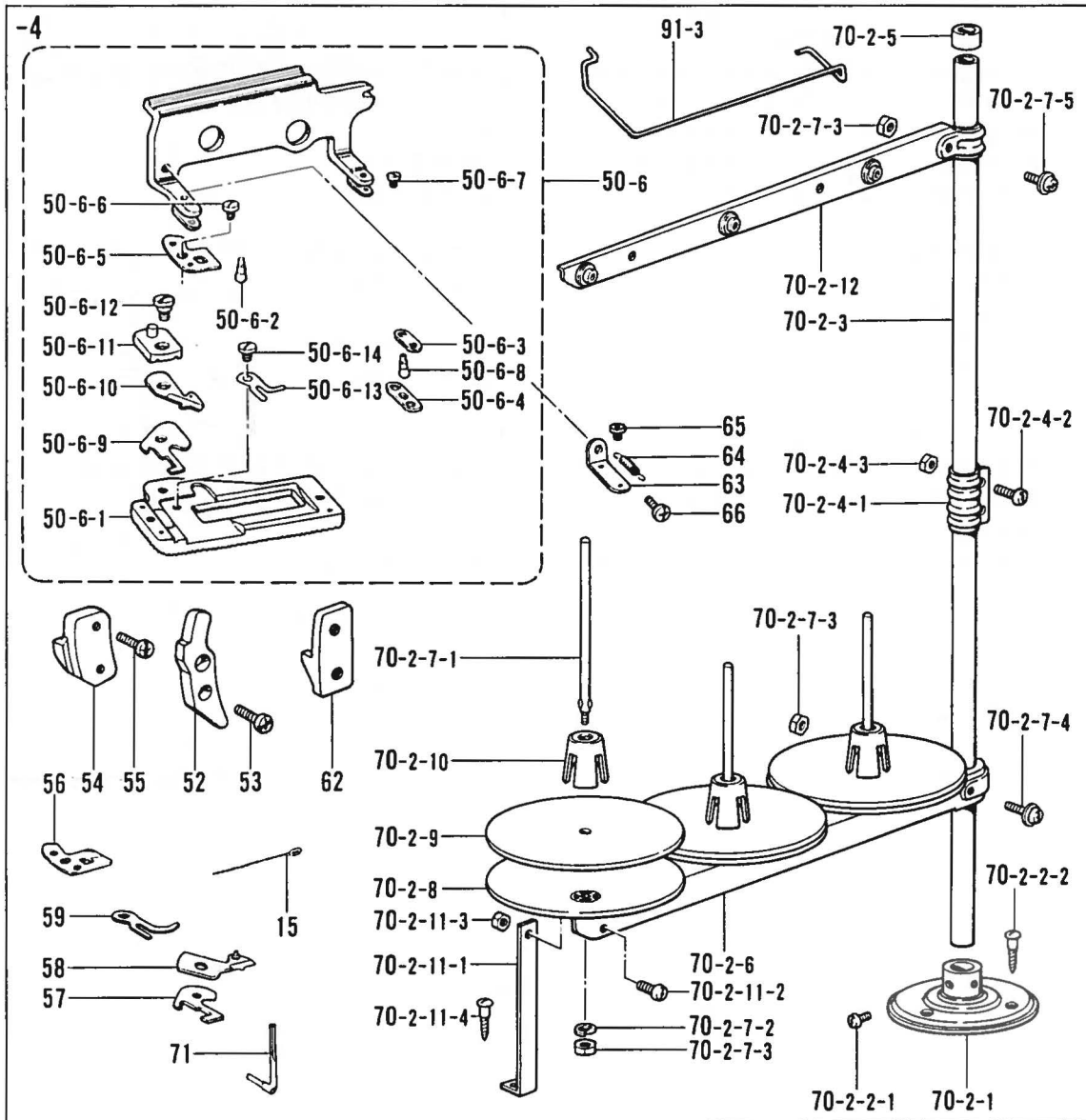
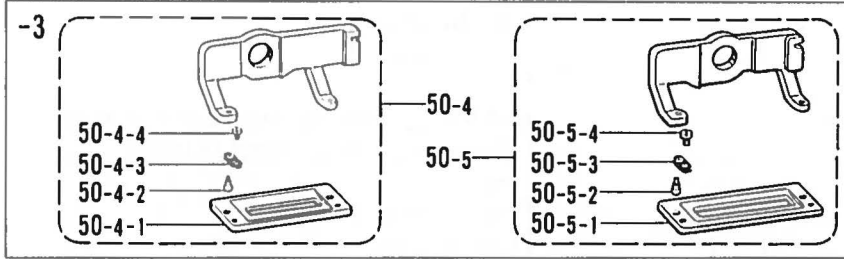
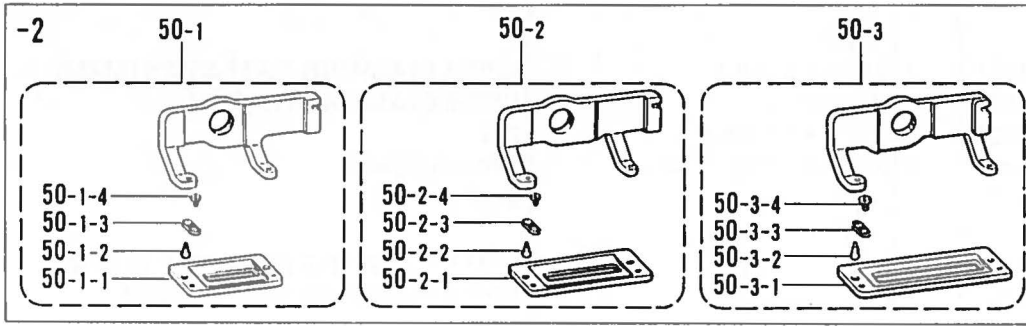

Z2 . 付属品関係/Accessories/Zubehör/Accessoires/Accesorios

REF.NO.	CODE	Q'TY	ヒンメイ	NAME OF PARTS	RM
<-4>					
15	111507000	1	イトトウシ	THREADER	
52	145352001	1	テイシカム	STOP CAM SEGMENT	
53	062680812	2	ナベコ437-40X8	SCREW, PAN M4.37-40X8	
54	145353001	1	カツターカム	CUTTER CAM SEGMENT	
55	062681012	2	ナベコ437-40X10	SCREW, PAN M4.37-40X10	
56	145366001	1	イトオサエ	THREAD PRESSER	
57	145367001	1	ヒモキリコテイバ	GIMP TRIMMING FIXED KNIFE	
58	145731001	1	ヒモキリイドウハクミ	GIMP TRIMMING MOVABLE KNIFE ASSY	
59	145373001	1	ヒモヨセレバ	GIMP DETACH LEVER	
62	145350001	1	フリカムF	ZIGZAG CAM SEGMENT (F)	
63	145991001	1	ヒモカケダイ	GIMP STOPPER	
64	511091001	1	ヒキバネ	SPRING, EXTENSION	
65	122771002	2	シメネジ2.38	SCREW 2.38	
66	062660412	1	ナベコ318-40X4	SCREW, PAN M3.18-40X4	
70-2	S02765109	1	イトタテダイクミ3	COTTON STAND ASSY 3	
70-2-1	150189109	1	ブラケット	BRACKET	
70-2-2	S02773001	1	ブラケットネジセット	COTTON STAND BRACKET SCREW SET	
70-2-2-1	062060806	2	ナベコ6X8	SCREW, PAN M6X8	
70-2-2-2	031452206	3	マルモク45X22	WOOD SCREW, ROUND M4.5X22	
70-2-3	150172003	2	コラムパイプ	COLUMN PIPE	
70-2-4	150106003	1	コラムジョイントクミ	COLUMN JOINT ASSY	
70-2-4-1	150173003	1	コラムジョイント	COLUMN JOINT	
70-2-4-2	062501406	2	ナベコ5X14	SCREW, PAN M5X14	
70-2-4-3	021500106	2	1シユナツト5	NUT, 1 M5	
70-2-5	150174000	1	コラムキャップ	COLUMN CAP	
70-2-6	S02779009	1	スプールホルダー3	SPOOL HOLDER 3	
70-2-7	S02782001	1	スプールネジセット3	SPOOL SCREW SET 3	
70-2-7-1	150179002	3	スプールジクB	SPOOL SHAFT (B)	
70-2-7-2	028050246	3	バネザガネ2-5	WASHER, SPRING 2-5	
70-2-7-3	021500106	5	1シユナツト5	NUT, 1 M5	
70-2-7-4	050503006	1	ナベコヒラザ5X30	SCREW, PAN (P WASHER) M5X30	
70-2-7-5	050501406	1	ナベコヒラザ5X14	SCREW, PAN (P WASHER) M5X14	
70-2-8	150180001	3	ウケザラ	SPOOL STAND BASE	
70-2-9	150182000	3	スプールのマット	SPOOL MAT	
70-2-10	126863001	3	スプールのクッション	SPOOL CUSHION	
70-2-11	S02784009	1	ホルダーササエAセット	HOLDER SUPPORT (A) SET	
70-2-11-1	150188009	1	スプールのホルダーササエA	SPOOL HOLDER SUPPORT (A)	
70-2-11-2	062501006	1	ナベコ5X10	SCREW, PAN M5X10	
70-2-11-3	021500106	1	1シユナツト5	NUT, 1 M5	
70-2-11-4	031452206	1	マルモク45X22	WOOD SCREW, ROUND M4.5X22	
70-2-12	S02788009	1	スレツドハンガークミ3	THREAD HANGER ASSY 3	
71	145380001	1	ヒモアンナイ	GIMP GUIDE PIPE	
91-3	150567000	1	-----	FINGER GUARD (L)	

◎ 付属品の明細は変更することがあります。
 ◎ The details of included accessories are subject to change.
 ◎ Änderungen in der Aufstellung der Mitgelieferten Zubehöre sind vorbehalten.
 ◎ Les détails des accessoires inclus sont sujets à des changements.
 ◎ Los detalles de los accesorios incluidos pueden variar.

仕様別部品一覧表/DIFFERENT PARTS LIST/ZUBEHÖRLISTE/
LISTE DES PIÈCES ACCESSOIRES/LISTA DE PIEZAS ACCESORIAS

REF.NO.	品名 PARTS	サブクラス	-2	-3	-4	-5
		SUB CLASS				
Z1-7	ミシンハリDPX5 NEEDLE DPX5		107415014 (#14)	107415011 (#11)	107415014 (#14)	←
Z1-16	カッター5/8 CUTTER 5/8		107205001	←	←	-----
Z1-16	カッター3/8 CUTTER 3/8		109837001	←	←	-----
Z1-16	カッター3/4 CUTTER 3/4		107207001	←	←	-----
Z1-16	カッター1 CUTTER 1		107210001	←	←	-----
Z1-16	カッター48 CUTTER 48		-----	-----	-----	147941001
Z1-18	チェンジギヤ28(個数:1) CHANGE GEAR 28 (Q'TY:1)		-----	-----	-----	141375000
Z1-18	チェンジギヤ30(個数:1) CHANGE GEAR 30 (Q'TY:1)		141376000	←	-----	141376000
Z1-18	チェンジギヤ32(個数:1) CHANGE GEAR 32 (Q'TY:1)		-----	-----	141377000	-----
Z1-18	チェンジギヤ34(個数:1) CHANGE GEAR 34 (Q'TY:1)		-----	141378000	-----	141378000
Z1-18	チェンジギヤ36(個数:1) CHANGE GEAR 36 (Q'TY:1)		141379000	←	←	-----
Z1-18	チェンジギヤ38(個数:2) CHANGE GEAR 38 (Q'TY:2)		141380000	-----	141380000	-----
Z1-18	チェンジギヤ40(個数:1) CHANGE GEAR 40 (Q'TY:1)		141381000	←	←	-----
Z1-18	チェンジギヤ42(個数:1) CHANGE GEAR 42 (Q'TY:1)		-----	141382000	-----	141382000
Z1-18	チェンジギヤ44(個数:1) CHANGE GEAR 44 (Q'TY:1)		-----	-----	141383000	-----
Z1-18	チェンジギヤ46(個数:1) CHANGE GEAR 46 (Q'TY:1)		141384000	←	-----	141384000
Z1-18	チェンジギヤ48(個数:1) CHANGE GEAR 48 (Q'TY:1)		-----	-----	-----	141385000

回転数別モータプーリとVベルト組合せ / MOTOR PULLEY AND V-BELT SELECTION /
 AUSWAHL DER RIEMENSCHLEIBEN UND ANTRIEBSRIEMEN / CHOIX DE LA POULIE DE MOTEUR ET DES
 COURROIES TRAPEZOIDALES / ELECCION DE POLEA DE MOTOR Y CORREA TRAPEZOIDAL

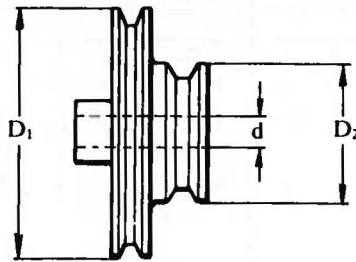

回転数 Machine speed	周波数 Frequency	モータプーリ Motor pulley		Ref.No. Z1-25	高速Vベルト High speed V-belt Ref.No.Z1-28	低速Vベルト Low speed V-belt Ref.No.Z1-28
		外径・内径 Outside inside diameter	穴径 Core	部品コード Parts No.		
3600	50Hz	D1 = 187.5 D2 = 79	d = 14	S33007-009	S18707-144(M44)	S18707-141(M41)
			d = 15.88	S33008-009		
	60Hz	D1 = 152.8 D2 = 56	d = 14	S31131-009	S18707-142(M42)	S18707-140(M40)
d = 15.88	S33009-009					
d = 19.05	S33010-009					
3200	50Hz	D1 = 160 D2 = 81	d = 14	141707-009	S18707-143(M43)	S18707-142(M42)
			d = 15.88	145781-009		
	60Hz	D1 = 134.2 D2 = 69.5	d = 14	141709-009	S18707-141(M41)	S18707-141(M41)
d = 15.88	145780-009					
d = 19.05	159830-009					
3000	50Hz	D1 = 152.8 D2 = 56	d = 14	S31131-009	S18707-142(M42)	S18707-140(M40)
			d = 15.88	S33009-009		
	60Hz	D1 = 127.6 D2 = 62.2	d = 14	S33254-009	S18707-140(M40)	S18707-140(M40)
d = 15.88	S33255-009					
d = 19.05	S33256-009					
2800	50Hz	D1 = 134.2 D2 = 69.5	d = 14	141709-009	S18707-141(M41)	S18707-141(M41)
			d = 15.88	145780-009		
	60Hz	D1 = 119.5 D2 = 69.5	d = 14	143890-009	S18707-141(M41)	S18707-140(M40)
d = 15.88	145782-009					
d = 19.05	159831-009					

ゲージ部品一覧表 / GAUGE PARTS LIST / LEHRENLISTE /
 LIST DES PIÈCES D'ECARTEMENT / LISTA DE PIEZAS CARIBRADORAS

チェンジギヤ / CHANGE GEAR

針数 Number of stitches	チェンジギヤL Change gear L	チェンジギヤR Change gear R	針数 Number of stitches	チェンジギヤL Change gear L	チェンジギヤR Change gear R
360	(54)141388-000	(22)141372-001	133	(36)141379-000	(40)141381-000
319	(52)141387-000	(24)141373-001	119	(34)141378-000	(42)141382-000
283	(50)141386-000	(26)141374-000	107	(32)141377-000	(44)141383-000
252	(48)141385-000	(28)141375-000	96	(30)141376-000	(46)141384-000
226	(46)141384-000	(30)141376-000	86	(28)141375-000	(48)141385-000
203	(44)141383-000	(32)141377-000	77	(26)141374-000	(50)141386-000
182	(42)141382-000	(34)141378-000	68	(24)141373-001	(52)141387-000
164	(40)141381-000	(36)141379-000	60	(22)141372-001	(54)141388-000
147	(38)141380-000	(38)141380-000			

カッター / Cutter

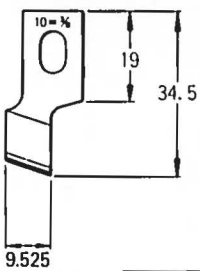
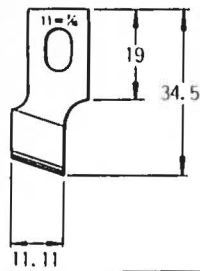
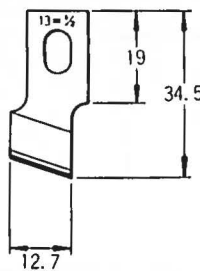
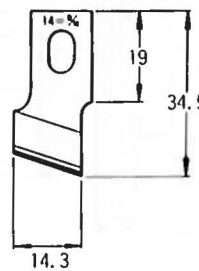
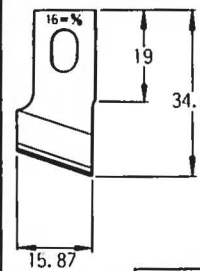
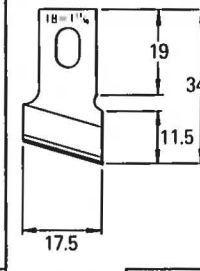
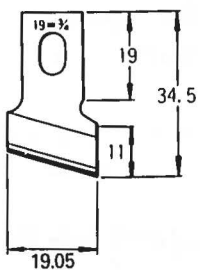
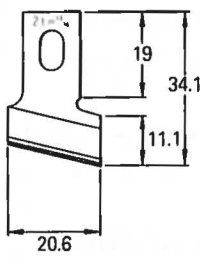
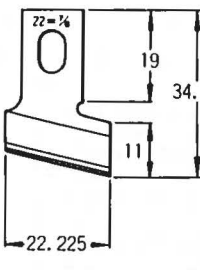
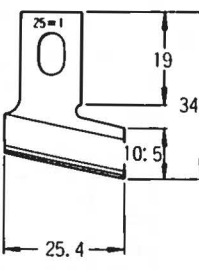
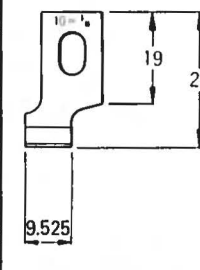
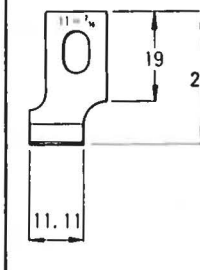
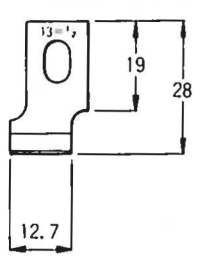
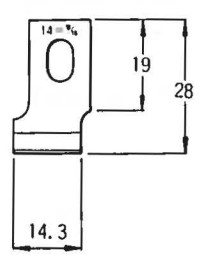
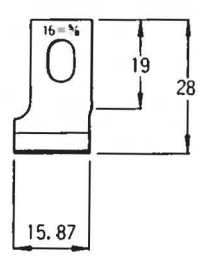
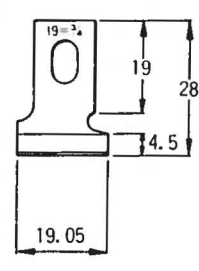
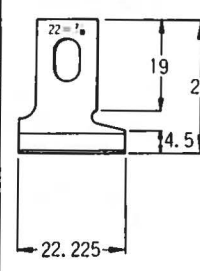
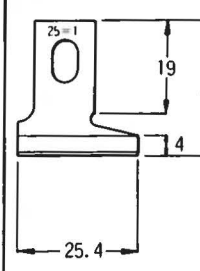
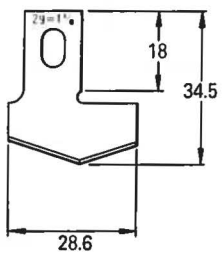
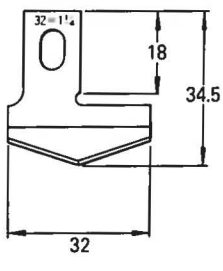
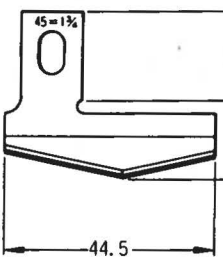
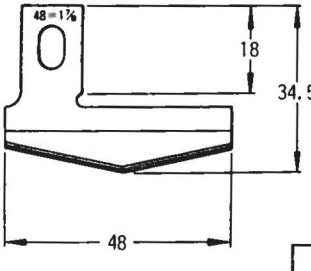
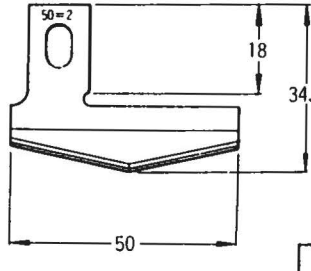
<p>109837-001</p>  <p>3/8</p>	<p>107204-001</p>  <p>7/16</p>	<p>107200-001</p>  <p>1/2</p>	<p>S03278-001</p>  <p>9/16</p>	<p>107205-001</p>  <p>5/8</p>	<p>S25641-001</p>  <p>11/16</p>
<p>107207-001</p>  <p>3/4</p>	<p>S25642-001</p>  <p>13/16</p>	<p>109838-001</p>  <p>7/8</p>	<p>107210-001</p>  <p>1</p>	<p>151837-001</p>  <p>3/8</p>	<p>151838-001</p>  <p>7/16</p>
<p>151839-001</p>  <p>1/2</p>	<p>S03279-001</p>  <p>9/16</p>	<p>151840-001</p>  <p>5/8</p>	<p>151841-001</p>  <p>3/4</p>	<p>153340-001</p>  <p>7/8</p>	<p>159722-001</p>  <p>1</p>
<p>S30294-001</p>  <p>29</p>		<p>143780-001</p>  <p>32</p>		<p>147987-001</p>  <p>45</p>	
<p>147941-001</p>  <p>48</p>		<p>147233-001</p>  <p>50</p>			

ヌノツカミクミ / Upper clamping foot assy

ヌノツカミ / Upper clamping foot

150763-001 16mm <-2> 145146-001 (ゴム/Rubber)	147112-001 16mm <-2> 147113-001	150764-001 25mm <-2> 144498-001 (ゴム/Rubber)
144493-001 25mm <-2> 144494-001	150765-001 32mm <-2> 144575-001 (ゴム/Rubber)	150767-001 16mm <-3> 145136-001 (ゴム/Rubber)
150768-001 25mm <-3> 144630-001 (ゴム/Rubber)	150769-001 32mm <-3> 144632-001 (ゴム/Rubber)	147721-001 16mm <-4> 147722-001 (ゴム/Rubber)
150770-001 25mm <-4> 145362-001	147719-001 25mm <-4> 147720-001 (ゴム/Rubber)	150771-001 32mm <-4> 145375-001
151610-001 16mm <-4> 151611-001 (薄物小穴用 / Thin materials)	150766-001 50mm <-5> 147230-001	

ハリイタクミ / Needle plate assy

ハリイタ / Needle plate

<-2> <-4>	147312-001 1.2mm	151612-001 1.2mm	145244-001 1.4mm
	147313-001	151613-001	145246-001
147314-001 1.6mm		ハリイタ O / Needle plate (O) 151842-001 1.2mm	ベースハリイタ U / Base plate (U) 145245-001
147315-001			
		カッターウケ / Plastic plate 151843-001 	

<-3>	144633-001 1.2mm	144636-001 1.4mm	144638-001 1.6mm
	144635-001	144637-001	144639-001
ハリイタ / Needle plate 156611-001 1.2mm		ベースハリイタ / Base plate 144634-001	
カッターウケ / Plastic plate 156612-001			

<-3>	ハリイタ / Needle plate 1.4mm 141536-001	<-5>	ハリイタ / Needle plate 1.4mm 147234-001

索引/INDEX/VERZEICHIS/
INDEX/INDICE

CODE	REF.NO.	Page
002301603	X1 - 1-1-20	58
	X1 - 1-2-8	58
	X2 - 1-4-7	62
002400803	X1 - 1-1-12	58
	X1 - 1-1-18	58
	X1 - 1-1-37	58
	X1 - 1-2-10	58
013670712	C - 20	8
	S - 41	38
013679412	U - 7-6	48
013711010	T - 30	44
013760612	D - 30	10
	L - 7	20
013760712	A - 70	2
013761410	R - 5	36
013771410	R - 13	36
013781012	F - 4	16
014760622	A - 54	2
	D - 10-1	10
	D - 50	10
	E - 60	14
	N - 8-3	30
	S - 6	38
	T - 38	46
	W - 15	54
	W - 29	54
014770622	B - 3	6
	B - 6	6
	B - 7	6
	B - 13	6
	C - 28	8
	D - 1-1	10
	D - 8-2	10
	D - 55	10
	E - 38	14
	E - 51-1	14
	G - 10	16
	K - 3	20
	N - 1-2	30
	N - 3-2	30
	P - 1-1	32
	P - 32	32
	Q - 24	34
	R - 1-1	36
	R - 1-2	36
	R - 6-1	36
	R - 7-1	36
	R - 7-2	36
	R - 11	36
	R - 14-1	36
	S - 17-1-1	38
	S - 17-2-1	38
	W - 32	54
	M1 - 33	22
	M1 - 39	22
	M1 - 45	22
	V2 - 76	52
014780622	P - 27	32
017681012	H - 8	18
	M1 - 62	24
	V2 - 95	52
017751412	P - 21	32

CODE	REF.NO.	Page
017761412	E - 4	14
017772012	P - 13	32
017781412	E - 7	14
017782512	E - 14	14
018061222	X1 - 1-1-34	58
018081422	M1 - 36	22
018082522	E - 36	14
	F - 2	16
018400832	Q - 30	34
	V1 - 29	50
	V2 - 99	52
018401222	Q - 27	34
018401622	V2 - 78	52
018503022	X1 - 1-1-6	58
021060106	X1 - 1-23	60
021060206	X1 - 1-1-35	58
021300103	X1 - 1-2-13	58
	X2 - 1-4-8	62
021400102	M1 - 15	22
021400106	Z1 - 29-3	66
021500103	X1 - 1-1-7	58
021500106	Z1 - 70-1-4-3	68
	Z1 - 70-1-7-3	68
	Z2 - 70-2-4-3	72
	Z2 - 70-2-7-3	72
	Z2 - 70-2-11-3	72
021660102	V1 - 35-1-5	50
	Z1 - 92-3	66
021710202	E - 22	14
021750102	G - 8	16
021860202	E - 28	14
021910302	M1 - 1-2	22
025030232	Z1 - 92-2	66
025030335	X1 - 1-2-14	58
025040233	X1 - 1-2-11	58
025050232	W - 19	54
025060232	S - 131	42
025060332	M2 - 22-2	26
025060336	X1 - 1-22	60
025080132	W - 70	56
	V2 - 111	52
025100132	E - 16	14
	E - 27	14
	E - 30	14
025350132	T - 34-1-6	46
025350332	K - 7-1-4	20
	K - 7-2-4	20
	L - 11	20
025680132	A - 38	2
	A - 45	2
025680232	H - 10	18
	Q - 16	34
	T - 12	44
	T - 15	44
	Y - 97-6	64
025710232	V1 - 34	50
025900232	M1 - 1-1	22
028050240	E - 21	14
028050246	Z1 - 70-1-7-2	68
	Z2 - 70-2-7-2	72
028060242	X1 - 1-24	60
031411304	X2 - 1-13	62

索引/INDEX/VERZEICHIS/
INDEX/INDICE

CODE	REF.NO.	Page
031452206	Z1 - 70-1-2-2	68
	Z2 - 70-2-2-2	72
	Z2 - 70-2-11-4	72
031553202	X1 - 1-12	60
047161042	S - 60	40
047250842	J - 1-19	18
047301842	P - 44	32
047400842	M2 - 26-3	26
048030342	J - 1-18	18
	W - 4	54
048040342	M1 - 42	22
048050342	M1 - 29	22
048060342	K - 7-1-2	20
	K - 7-2-2	20
	S - 129-1	42
	V1 - 11	50
	V2 - 72	52
048070342	E - 62	14
	G - 22	16
048080342	P - 49	32
048090342	J - 1-7	18
048100142	E - 17	14
	E - 31	14
048110142	D - 58	10
048150142	C - 16	8
048200142	F - 3-4	16
048250142	C - 15	8
050501406	Z1 - 70-1-7-5	68
	Z2 - 70-2-7-5	72
050503006	Z1 - 70-1-7-4	68
	Z2 - 70-2-7-4	72
060660512	V2 - 68	52
060660516	T - 63-6	46
060670512	K - 7-1-5	20
	K - 7-2-5	20
	T - 35	44
060670612	L - 5	20
	Q - 38	34
060670616	S - 125	40
060670812	V2 - 103	52
062060806	Z1 - 70-1-2-1	68
	Z2 - 70-2-2-1	72
062301405	X2 - 1-5-3	62
062401416	Z1 - 29-4	66
062501006	Z2 - 70-2-11-2	72
062501406	Z1 - 70-1-4-2	68
	Z2 - 70-2-4-2	72
062660412	S - 71	40
	T - 67	46
	Y - 96-1-12	64
	M1 - 54	22
	Z2 - 66	72
062670412	A - 87	4
	T - 34-1-4	46
	V1 - 19	50
062670512	A - 50	2
	S - 24	38
	S - 44	38
	S - 74	40
	S - 88	40
	S - 108	40
	S - 111	40
	T - 43	44

CODE	REF.NO.	Page
062670612	A - 52	2
	D - 18	10
	J - 1-10	18
	S - 34	38
	S - 37	38
	T - 34-1-2	46
	W - 49	54
	M1 - 21	22
	X2 - 1-8	62
062670812	P - 46	32
	Q - 43	34
	S - 32	38
	S - 51	38
	S - 55	38
	S - 59	40
062671212	J - 1-13	18
062680512	A - 76-3	2
	A - 76-5	2
	N - 21	30
	R - 16	36
	Y - 97-2	64
	Y - 97-4	64
	V2 - 65	52
062680612	S - 76	40
	S - 78	40
	S - 148	42
	M1 - 50	22
	V2 - 89	52
	V2 - 93	52
062680712	A - 62	2
	D - 15	10
	P - 37	32
	S - 89	40
	U - 7-17	48
	V1 - 27	50
	V1 - 36	50
	X2 - 1-10	62
062680812	G - 12	16
	G - 19	16
	J - 4	18
	P - 16	32
	Q - 35	34
	T - 11	44
	M2 - 4-2-8	26
	M2 - 4-2-10	26
	Z2 - 53	72
062681012	A - 34	2
	K - 8	20
	T - 41	44
	M1 - 4-1-2	24
	M1 - 4-1-8	24
	M1 - 4-1-10	24
	M2 - 4-2-6	26
	M2 - 4-2-12	26
	V1 - 38	50
	Z2 - 55	72
062681212	A - 44	2
	C - 5	8
	W - 25	54
	M1 - 4-1-4	24
	M1 - 4-1-6	24
	M2 - 4-2-2	26
	M2 - 4-2-4	26

索引/INDEX/VERZEICHIS/
INDEX/INDICE

CODE	REF.NO.	Page
062681412	A -33	2
	A -37	2
	P -39	32
062681612	X2 -1-7	62
062682012	M1 -60	24
062710616	A -74	2
062710812	V1 -33	50
062711012	G -21	16
062711212	Q -13	34
062711412	D -40-2	10
	E -48	14
	F -3-2	16
	S -141	42
062751612	W -34	54
062761012	E -34	14
	E -42	14
	W -10	54
	M1 -27	22
062761212	D -34	10
	E -54	14
	P -7	32
	S -130	42
	U -8	48
	W -50	54
	M1 -2	22
	V1 -14	50
062762012	A -17	2
	A -21	2
072600040	J -1-2	18
072600560	C -12	8
072620260	C -6	8
081014670	S -93	40
100022005	V1 -4	50
	V1 -7	50
	V1 -112	50
100032004	W -57	54
100075004	E -65	14
100090004	X1 -1-1-4	58
100136001	T -7	44
	T -26-2	46
	T -62	46
	Y -96-2-4	64
100197002	V2 -71	52
100250001	B -2	6
100251001	S -3	38
100257010	S -91	40
100281001	K -5	20
	V1 -10	50
100366002	K -7-1-3	20
	K -7-2-3	20
	Q -4	34
100398001	T -20	46
100399001	T -21	44
100400000	T -23	46
100402004	T -28	44
100511003	D -39	10
100644005	T -14	44
	V2 -101	52
100645003	M1 -63	24
	M1 -67	24
	V2 -108	52
	X2 -1-15	62
100659001	U -7-10	48

CODE	REF.NO.	Page
100661001	U -7-9	48
100887001	Z1 -4-1	66
101118001	X1 -1-20	60
101125000	Z1 -38	66
101572101	Z1 -3-3	66
101671002	L -9	20
	U -15	48
101706001	C -29	8
101706003	M1 -46-1	22
102571003	W -62	56
102707002	D -17	10
102716003	T -63-5	46
102843004	C -9	8
	C -14	8
	Q -40	34
102850002	T -19	44
103950003	S -96	40
104449009	S -102	40
104450109	S -30	38
104564001	S -99	40
104821009	S -45	38
104833009	W -27	54
104847001	W -28	54
104848001	D -11-1	10
104908002	Z1 -26	66
105073001	X2 -1-14	62
105161003	T -34-1-1	46
105161004	A -13	2
105234003	Y -96-1-2	64
105288002	T -58	46
105423001	W -42	56
105451001	D -47	10
105812002	D -45	10
105812003	W -59	56
105955002	Y -96-1-8	64
105970001	M1 -12	22
106147002	M1 -65	24
106568003	D -20	10
106588003	D -28	10
	P -10	32
	M2 -31-2	26
106629002	W -20	54
107017002	A -27	2
	A -41	2
107097101	R -19-2	36
	R -19-2	36
107126001	P -53	32
107153001	S -15	38
107153002	E -61	14
107200001	P -40-1	32
107204001	P -40-2	32
107205001	P -40-3	32
	Z1 -16	66
107207001	Z1 -16	66
107210001	Z1 -16	66
107231002	A -76-7	2
107321003	A -26	2
	A -40	2
107372001	A -76-6	2
107401001	M3 -47-1-3	28
	M3 -47-3-3	28
	M3 -47-4-3	28
	Z2 -50-1-3	70

索引/INDEX/VERZEICHIS/
INDEX/INDICE

CODE	REF.NO.	Page
107401001	Z2 - 50-2-3	70
	Z2 - 50-3-3	70
	Z2 - 50-6-3	70
107404001	M3 - 47-1-4	28
	M3 - 47-2-4	28
	M3 - 47-3-7	28
	M3 - 47-4-4	28
	Z2 - 50-1-4	70
	Z2 - 50-2-4	70
	Z2 - 50-3-4	70
	Z2 - 50-4-4	70
	Z2 - 50-5-4	70
	Z2 - 50-6-7	70
107407003	A - 67	4
	B - 15	6
	H - 2	18
	P - 50-2	32
	Q - 6	34
	Q - 8	34
	Q - 19	34
	U - 2	48
	Y - 96-3	64
	V1 - 22	50
	V1 - 31	50
	V2 - 84	52
107415011	B - 9-1	6
	Z1 - 7	66
107415014	B - 9-2	6
	Z1 - 7	66
107419002	S - 83	40
107453001	P - 20	32
107550002	M1 - 24	22
107602001	T - 3	44
107606001	T - 25	46
107612001	T - 8	44
107639001	V1 - 40	50
107640001	Q - 21	34
107657001	V2 - 106	52
107678101	U - 3	48
107680001	U - 4	48
107681001	U - 5	48
107682001	U - 6	48
107744001	W - 3	54
108494001	Y - 96-2-2	64
108495001	Y - 96-2-3	64
108520009	S - 126	40
109173101	R - 18-3	36
109183001	S - 40	38
109203001	S - 95	40
109208001	R - 4	36
109837001	Z1 - 16	66
109862001	S - 43	38
109893002	P - 12	32
110067001	Y - 96-1-9	64
110104000	S - 50-1	38
110161004	Q - 7-3	34
	W - 54	54
	V1 - 24	50
110185002	J - 1-5	18
110215002	X2 - 1-4-5	62
110367001	B - 4	6
110641002	S - 94	40
110744002	P - 18	32

CODE	REF.NO.	Page
110813001	T - 53	46
111073001	W - 56-2-3	56
111105001	M3 - 47-3-6	28
	Z2 - 50-6-6	70
111237001	B - 5-1-3	6
	B - 5-2-3	6
111443003	Q - 2	34
111468001	B - 5-1-6	6
	B - 5-2-5	6
111507000	Z2 - 15	72
111920000	W - 71	56
111937009	F - 5	16
112144001	P - 52	32
112359001	S - 61	40
112467002	S - 133-8	42
112743001	S - 122	40
112744001	S - 23	38
112751003	T - 32	44
113730001	X2 - 1-4-3	62
113897001	V2 - 104	52
	V2 - 109	52
114294001	S - 117	40
114747001	A - 55	2
115120001	M2 - 69	26
115188001	T - 6-1	46
115493002	Q - 33	34
	W - 16	54
115503001	P - 41	32
115544001	E - 18	14
115545001	E - 19	14
115546001	E - 20	14
115550001	E - 25	14
115551001	E - 26	14
115552001	E - 29	14
115558002	E - 40	14
115559002	E - 41	14
115585001	E - 45	14
	G - 5	16
	W - 6	56
115958001	T - 52	46
	T - 61	46
116016001	Z1 - 29-2	66
116185209	Z1 - 29	66
116662003	A - 47	2
	Y - 97-5	64
116725009	S - 104	40
116735000	B - 5-1-7	6
	B - 5-2-6	6
116755001	V2 - 63	52
	V2 - 91	52
116795000	S - 116	40
116968001	S - 50-5	38
116975001	S - 73	40
	S - 124	40
117215001	T - 6-2	46
117348001	C - 26	8
117437109	Z1 - 29-1	66
117466000	Z1 - 10	66
117598001	S - 115	40
117934009	A - 72	2
118215001	M1 - 41	22
118244001	V2 - 62	52
118262002	M1 - 31-1	24

索引/INDEX/VERZEICHIS/
INDEX/INDICE

CODE	REF.NO.	Page
118352001	V1 -35-1-6	50
118735002	E -6	14
	E -13	14
	M1 -66	22
118759001	R -14	36
118764002	U -9	48
118837001	Z1 -3-2	66
119755001	X1 -1-21	60
120774001	S -119	40
120790001	P -54	32
122771002	T -66	46
	Y -96-1-4	64
	Y -96-1-7	64
	Z2 -65	72
122991001	Z1 -1	66
126863001	Z1 -70-1-10	68
	Z2 -70-2-10	72
129986001	A -42	2
140004001	B -5-1-4	6
	B -5-2-4	6
140025002	W -61	56
140326009	B -18	6
140430001	B -5-1-8	6
	B -5-2-7	6
140553102	B -10	6
140647001	S -152	42
140649001	W -66	56
140650001	W -67	56
140651001	W -68	56
140678001	X1 -1-1-39	58
140947002	M1 -14	22
141243109	A -4	2
141244100	A -5	2
141246001	A -76-2	2
141247001	A -76-4	2
141248001	A -12	2
141249109	A -16	2
141252000	A -23	2
141254000	A -24	2
141256001	Z1 -39	66
141257001	A -29	2
141258009	A -30	2
141259009	A -31	2
141262001	A -36	2
141263104	A -39-1	4
141267001	A -48	2
141269001	A -51-1	4
141271001	C -1	8
141272001	C -2	8
141273000	C -3	8
141274000	C -4	8
141275001	C -7	8
141276001	C -8	8
141277000	C -10	8
141278001	C -11	8
141279001	C -13	8
141280001	C -17	8
141281001	C -18	8
141282001	C -19	8
141283001	C -21	8
141284000	C -22	8
141285001	C -23	8
141286001	C -24	8

CODE	REF.NO.	Page
141289001	C -25	8
141290000	B -1	6
141295001	B -12	6
141296001	B -14	6
141297101	R -2	36
141298000	R -3	36
141303000	R -8	36
141304001	R -10	36
141305000	R -12	36
141307001	R -19-1	36
141308101	R -15	36
141310001	D -3	10
141311000	D -4	10
141312000	D -6	10
141313101	D -8-1	10
141316001	J -1-4	18
141326001	D -11-2	10
141328000	D -14	10
141329001	D -16	10
141332001	D -19	10
141333001	D -21	10
141334001	D -22	10
	D -52	10
	E -43	14
	E -64	14
141335000	D -23	10
141336001	D -24	10
141337001	D -25	10
141338001	D -26	10
141339001	D -27	10
141340001	D -29	10
141341001	D -31	10
141342000	D -32	10
141344001	D -35	10
141345001	D -36	10
141346001	D -38	10
141347001	D -40-1	10
141348001	D -42	10
141351001	D -54	10
141354000	D -43	10
141355001	D -44	10
141356001	D -46	10
141357000	D -49	10
141358001	D -51	10
141359001	D -53	12
	D -53	12
141363001	D -57	10
141365000	D -61	12
	D -61	12
141366001	D -62	12
	D -62	12
141367001	N -1-1	30
141368000	N -3-1	30
141369101	N -5	30
141374000	N -7-1	30
141375000	Z1 -18	66
141376000	Z1 -18	66
141377000	N -7-1	30
	Z1 -18	66
141378000	N -7-1	30
	Z1 -18	66
141379000	Z1 -18	66

索引/INDEX/VERZEICHIS/
INDEX/INDICE

CODE	REF.NO.	Page
141380000	Z1 - 18	66
141381000	Z1 - 18	66
141382000	N - 7-2	30
	Z1 - 18	66
141383000	N - 7-2	30
	Z1 - 18	66
141384000	Z1 - 18	66
141386000	N - 7-2	30
141389001	N - 8	30
141392001	N - 8-1	30
141393001	N - 8-2	30
141394001	N - 9	30
141396001	N - 11	30
141397001	N - 12	30
141398009	N - 13	30
141399001	N - 14	30
141400009	N - 16	30
	M1 - 6	22
141401001	M1 - 1	22
141404000	M1 - 3	22
141408009	M1 - 7	22
141409001	M1 - 8	22
141410001	M1 - 9	22
141411001	M1 - 10	22
141412001	M1 - 11	22
141413001	M1 - 13	22
141417009	P - 26	32
	M1 - 18	22
141419001	M1 - 22-1	24
141420001	M1 - 23	22
141421009	M1 - 25	22
141422001	M1 - 26-1	24
141426001	M1 - 32	22
141427009	M1 - 34-1	24
141429001	M1 - 37	22
141430009	M1 - 38	22
141431001	M1 - 40	22
141433009	M1 - 43-1	24
141434001	M1 - 44-1	24
141439001	M1 - 48	22
141440001	M1 - 49-1	24
141441001	M1 - 51	22
141442001	M1 - 53	22
141445001	M1 - 4-1-5	24
141446001	M1 - 4-1-7	24
141448001	M1 - 4-1-9	24
141449001	K - 1	20
141450001	K - 2	20
141451001	K - 4	20
141454009	K - 6	20
141455001	K - 7-1	20
141462001	P - 4	32
141463001	P - 5	32
	V1 - 12	50
141464101	P - 8	32
141465001	P - 9	32
141466001	P - 11	32
141467001	P - 14	32
141469001	P - 17	32
141471001	P - 22	32
141472002	G - 14	16
	P - 23	32

CODE	REF.NO.	Page
141472002	W - 12	54
	V1 - 39	50
141473009	P - 24	32
141474001	P - 31	32
141475001	P - 33	32
141476001	P - 34	32
141478001	P - 36	32
141479001	P - 38	32
141480001	P - 50-1	32
141481001	P - 29	32
141484001	P - 42	32
141485001	P - 43	32
141486001	P - 45	32
141487001	P - 47	32
141488001	P - 48	32
141489001	V1 - 1	50
141490001	V1 - 2	50
141491001	V1 - 3	50
141492001	V1 - 5	50
	V1 - 113	50
141494001	V1 - 6	50
	V1 - 114	50
141496001	V1 - 9	50
141497001	V1 - 15	50
141499001	V1 - 17	50
141500001	V1 - 18	50
141501001	V1 - 20	50
141502001	V1 - 21	50
141504001	Q - 7-2	34
	V1 - 23	50
141505001	V1 - 25	50
141506001	V1 - 26	50
141508001	V1 - 30	50
141509101	V1 - 32	50
	Z1 - 19	68
141510101	V1 - 32-1	50
	Z1 - 19-1	68
141511000	Z1 - 19-2	68
141511001	V1 - 32-2	50
141512101	V1 - 32-3	50
	Z1 - 19-3	68
141513001	V1 - 32-4	50
	Z1 - 19-4	68
141514001	V1 - 32-5	50
	Z1 - 19-5	68
141515001	V1 - 35-1-1	50
141516001	V1 - 37	50
141517101	V1 - 41	50
141518009	W - 1	56
141519001	W - 5	54
141520001	W - 8	54
141521001	W - 11	56
141522001	W - 13	54
141523001	W - 17	54
141526001	W - 18	54
141527001	W - 21	56
141528001	W - 22	54
141529000	W - 24	54
141530001	W - 26	54
141531001	W - 30	54
141532001	W - 31	54
141533001	W - 33	54
141534001	W - 35	54

索引/INDEX/VERZEICHIS/
INDEX/INDICE

CODE	REF. NO.	Page
141535001	W -36	54
141537001	W -38-1	56
141538001	W -39	56
141539001	W -40	56
141541001	W -44	54
141542001	W -45	54
141543001	W -46	54
141544001	W -47	54
141545001	W -48	54
141546001	E -1	14
141547001	E -3-1	14
141548001	E -5	14
141549001	E -9	14
141550001	E -10	14
141553001	E -12	14
141554001	E -23	14
141555001	E -32	14
141556101	E -33	14
141557002	E -35	14
141558001	E -37	14
141559001	E -39	14
141562101	E -50	14
141564001	E -53	14
141566001	F -3	16
141574001	G -1	16
141575001	G -2	16
141576001	G -7	16
141579001	G -9	16
141580001	G -11	16
141581001	G -13	16
141582001	G -15	16
141583001	G -16	16
141584001	G -17	16
141586001	G -17-1	16
141588001	G -18	16
141589001	G -20	16
141590001	T -1	46
141592001	T -10	44
141593001	T -13	44
141594001	T -33	44
141596009	T -36	46
141597001	T -37	46
141598001	T -39	46
141599009	T -40	46
141600001	U -1	48
141601009	U -7	48
141602009	U -7-1	48
141603009	U -7-2	48
141604001	U -7-3	48
141605001	U -7-5	48
141606001	U -7-7	48
141607001	U -7-8	48
141608001	U -7-11	48
141609009	U -7-13	48
141610001	U -7-14	48
141611001	U -7-15	48
141614001	L -1	20
141616001	L -3	20
141617001	L -4	20
141618001	E -8	14
141619001	L -6	20
141620001	L -8	20
	U -14	48

CODE	REF. NO.	Page
141621001	J -1	18
141622000	J -1-1	18
141623001	J -1-6	18
141624001	J -1-8	18
141625001	J -1-9	18
141627001	J -1-12	18
141628001	J -1-14	18
141629001	J -1-15	18
141630001	J -1-16	18
141631001	J -1-17	18
141632101	J -2	18
141633001	J -3	18
141636000	S -1	38
141637000	S -2	38
141642000	S -133-1	42
141643000	S -133-2	42
141647000	S -21	38
141651001	S -28	38
141652001	S -29	38
141653001	S -31	38
141654001	S -33	38
141655000	S -35	38
141656001	S -36	38
141659001	D -56	10
141661001	S -50	38
141663001	S -50-2	38
141664001	S -50-3	38
141665001	S -50-4	38
141666001	S -50-6	38
141667001	S -50-7	38
141668001	S -50-8	38
141669000	S -50-9	38
141670000	S -53	38
141671001	S -54	38
141672000	S -56	38
141674001	S -58-1	38
141679001	S -66	40
141680001	S -68	40
141681000	S -69	40
141682001	S -70	40
141683000	S -72	40
141685001	S -75	40
141686001	S -77	40
141687000	S -79	40
141688001	S -80	40
141689101	S -82	40
141692001	S -86	40
141696001	S -92	40
141697000	S -105	40
	S -149	42
141698001	H -1	18
141699001	H -3	18
141700001	H -4	18
141701001	H -5	18
141702001	H -6	18
141703001	H -7	18
141704001	H -9	18
141705001	Y -97-1	64
141707009	Z1 -25	66
141711100	Z1 -27	66
141714001	N -6	30
141716000	D -60	12
	D -60	12
141717001	P -2	32

索引/INDEX/VERZEICHIS/
INDEX/INDICE

CODE	REF.NO.	Page
141718001	A - 53	2
141953001	E - 58	14
142214001	E - 59	14
142258001	T - 42	44
142259001	U - 7-4	48
142268001	S - 107	40
142269000	A - 28	2
142272001	N - 18	30
142273001	N - 19	30
142297001	C - 27	8
142298000	S - 110	40
142312001	A - 61	2
142342000	J - 1-3	18
142351101	S - 26	38
142352101	S - 38	38
142353101	S - 47	38
142354101	S - 62	40
142355101	S - 64	40
142359001	S - 20	38
	S - 49	38
	S - 52	38
	S - 57	38
142372000	E - 2	14
	W - 2	54
	M1 - 17	22
142373000	E - 55	14
	G - 4	16
	W - 52	54
142374000	M1 - 35	22
142375000	M1 - 5	22
142376000	P - 25	32
142407001	S - 42	38
142408001	S - 112	40
142413001	S - 58	38
142416001	W - 43	54
142419001	W - 51	54
142420001	W - 53	54
142443001	Z1 - 3-1	66
142582001	S - 113-1	40
142667101	E - 15	14
142702001	N - 17	30
142711001	U - 7-18	48
142721001	Z1 - 6	66
142724001	P - 50	32
142733001	T - 29	44
142734001	Z1 - 68	66
142735001	T - 31	44
142736001	B - 11	6
142742000	S - 118	40
142743009	A - 2	2
142744001	R - 18-2	36
142745002	Z1 - 17	66
142748001	S - 25	38
142748002	S - 145	42
142750001	S - 22	38
142750002	S - 144	42
142751001	C - 30	8
142755001	E - 56	14
142766001	S - 5	38
142771001	E - 63	14
142779001	P - 51	32
143394001	W - 65	56
143713101	S - 120	40

CODE	REF.NO.	Page
143714001	S - 121	40
143715001	S - 121-1	40
143716001	S - 121-2	40
143738009	M1 - 59	24
143739009	M1 - 16-1	24
143740001	M1 - 20-1	24
143741001	A - 66	4
143742001	A - 65	4
143743001	M1 - 64-1	24
143748001	Y - 96-1-11	64
143749001	Y - 96-1-10	64
143767009	Y - 96-2	64
143788001	W - 14	54
	V2 - 75	52
	V2 - 80	52
143793001	R - 18-1	36
143890009	Z1 - 25	66
143914001	J - 1-20	18
143915001	S - 17	38
143916001	S - 17-1	38
143917001	J - 1-11	18
143927001	P - 28	32
143933001	R - 18	36
143942101	M1 - 4-1	24
143943001	M1 - 4-1-1	24
143944001	M1 - 4-1-3	24
143945001	P - 19	32
143949001	Z1 - 4-2	66
143971001	Z1 - 92	66
143980001	Y - 96-2-1	64
143982001	S - 4	38
143983001	S - 18	38
143984009	A - 20	2
143985101	A - 25	2
143986101	R - 19	36
144226001	Z1 - 40	66
144496001	M3 - 47-1-2	28
	M3 - 47-2-2	28
	M3 - 47-3-2	28
	M3 - 47-4-2	28
	Z2 - 50-1-2	70
	Z2 - 50-2-2	70
	Z2 - 50-3-2	70
	Z2 - 50-4-2	70
	Z2 - 50-5-2	70
	Z2 - 50-6-2	70
144498001	M3 - 47-1-1	28
	Z2 - 50-2-1	70
144504001	T - 63-3	46
144505000	T - 63-4	46
	U - 12	48
144541001	M1 - 55	24
144575001	Z2 - 50-3-1	70
144627001	M2 - 61-2	26
144628001	Y - 96-1-6	64
144630001	M3 - 47-2-1	28
144632001	Z2 - 50-5-1	70
144633001	W - 56-2	56
144634001	W - 56-2-1	56
144635001	W - 56-2-2	56
144707001	M3 - 47-2-3	28
	Z2 - 50-4-3	70
	Z2 - 50-5-3	70
144741001	T - 18	44

索引/INDEX/VERZEICHIS/
INDEX/INDICE

CODE	REF.NO.	Page
144876001	S - 133-7	42
144946000	A - 19	2
144997001	Y - 96-1-3	64
144998001	Y - 96-1-1	64
144999001	Y - 96-1-5	64
145136001	Z2 - 50-4-1	70
145146001	Z2 - 50-1-1	70
145244001	W - 56-1	56
145245001	W - 56-1-1	56
145246001	W - 56-1-2	56
145247001	W - 56-1-3	56
145248001	M1 - 61-1	24
145342009	A - 71	4
145344001	D - 59	12
145345001	A - 51-2	4
145348001	M2 - 4-2-1	26
145350001	M2 - 4-2-5	26
	Z2 - 62	72
145351001	M2 - 4-2-7	26
145352001	M2 - 4-2-9	26
	Z2 - 52	72
145353001	M2 - 4-2-11	26
	Z2 - 54	72
145354009	M2 - 34-2	26
145355001	M2 - 44-2	26
145356009	M2 - 43-2	26
145357001	M2 - 61-3	26
145358001	M2 - 64-2	26
145359001	M2 - 20-2	26
145362001	M3 - 47-3-1	28
145365001	M3 - 47-3-4	28
	Z2 - 50-6-4	70
145366001	M3 - 47-3-5	28
	Z2 - 50-6-5	70
	Z2 - 56	72
145367001	M3 - 47-3-9	28
	Z2 - 50-6-9	70
	Z2 - 57	72
145369001	M3 - 47-3-11	28
	Z2 - 50-6-11	70
145370001	M3 - 47-3-12	28
	Z2 - 50-6-12	70
145371001	M3 - 47-3-14	28
	Z2 - 50-6-14	70
145373001	M3 - 47-3-13	28
	Z2 - 50-6-13	70
	Z2 - 59	72
145375001	Z2 - 50-6-1	70
145377001	K - 7-2	20
145380001	Q - 1	34
	Z2 - 71	72
145381001	Q - 3	34
145382001	Q - 5	34
145383101	Q - 7	34
145384001	Q - 9	34
145385001	Q - 10	34
145386001	Q - 11	34
145387001	Q - 12	34
145388001	Q - 15	34
145392001	Q - 18	34
145394001	Q - 23	34
145395001	Q - 25	34
145397001	Q - 28	34
145398101	Q - 29	34

CODE	REF.NO.	Page
145399001	Q - 31	34
145400009	Q - 32	34
145401001	Q - 34	34
145402009	Q - 36	34
145403001	Q - 37	34
145404001	Q - 39	34
145405001	Q - 41	34
145406001	Q - 42	34
145407001	V2 - 61	52
145411001	V2 - 64	52
145412001	V2 - 66	52
145413001	V2 - 67	52
145414001	V2 - 100	52
145415001	V2 - 69	52
145416001	V2 - 70	52
145417001	V2 - 74	52
145418009	V2 - 77	52
145419001	V2 - 79	52
145420001	V2 - 82	52
145421001	V2 - 83	52
145426009	V2 - 86	52
145427001	V2 - 87	52
145428001	V2 - 88	52
145429001	V2 - 90	52
145430001	V2 - 92	52
145431001	V2 - 94	52
145433001	V2 - 96	52
145434001	V2 - 97	52
145435001	V2 - 98	52
145436001	V2 - 102	52
145437001	T - 51	46
145438009	T - 54	46
145439001	T - 55	46
145440001	T - 57	46
145441001	Y - 96-1-13	64
145442001	E - 3-2	14
145445001	M2 - 26-2	26
145446001	T - 4	44
	T - 22	44
	T - 59	46
145465001	B - 5-1-1	6
	B - 5-2-1	6
	S - 133-5	42
145486001	X1 - 1-1-3	58
145673001	T - 9	44
145692001	Q - 14	34
145719101	B - 5-2	6
145723001	T - 63	46
145724001	T - 63-1	46
145725001	T - 63-2	46
145731001	M3 - 47-3-10	28
	Z2 - 50-6-10	70
	Z2 - 58	72
145732001	V2 - 85	52
145780009	Z1 - 25	66
145781009	Z1 - 25	66
145782009	Z1 - 25	66
145931001	G - 23	16
145961001	T - 16	44
145983001	V2 - 110	52
145991001	T - 64	46
	Z2 - 63	72
145998001	V1 - 16	50
145999001	V1 - 35-1	50
146000001	V1 - 35-1-2	50

索引/INDEX/VERZEICHIS/
INDEX/INDICE

CODE	REF.NO.	Page
146001001	V1 - 35-1-3	50
146002001	V1 - 35-1-4	50
146011001	W - 69	56
146025001	R - 20	36
	Z1 - 9	66
146034001	M3 - 47-3-8	28
	Z2 - 50-6-8	70
146041002	E - 11	14
146075001	B - 8-2	6
146130001	M2 - 4-2-13	26
146198001	U - 10	48
146199001	U - 11	48
146200001	U - 13	48
146209101	S - 127	40
146253000	L - 10	20
146254001	Z1 - 37	66
146316001	Q - 17	34
146336001	M2 - 4-2	26
146338001	M2 - 4-2-3	26
146355001	R - 9	36
146951001	Q - 20	34
146955004	E - 44	14
147155000	D - 64	10
147156001	Y - 97-3	64
147202104	A - 39-2	4
147222109	F - 1	16
147223001	S - 129	42
147226001	S - 128	40
147228009	M2 - 43-3	26
147229009	M2 - 16-2	26
147230001	M3 - 47-4-1	28
147232001	M2 - 49-2	26
147234001	W - 56-3	56
147235001	W - 38-2	56
147236001	W - 60	56
147317001	N - 20	30
147558001	V1 - 35-2	50
147565001	V1 - 8	50
147639001	E - 24	14
147758001	Q - 7-1	34
147901001	D - 11	10
147939001	M2 - 26-4	26
147941001	P - 40-4	32
	Z1 - 16	66
147945001	M1 - 28	22
147985001	R - 18-4	36
148054001	R - 21	36
148058001	T - 34-1-3	46
148469001	S - 133-3	42
148470001	S - 133-4	42
148471001	S - 133-6	42
148472001	S - 143	42
148745000	S - 146	42
148746001	S - 147	42
148761001	S - 133	42
148831001	T - 34-1	46
149095001	D - 33	10
	P - 6	32
	W - 9	54
	V1 - 13	50
149247001	Z1 - 33	66
149288003	W - 72	54
149488001	X1 - 1-2-5	58

CODE	REF.NO.	Page
149488001	X1 - 1-3-3	60
150106003	Z1 - 70-1-4	68
	Z2 - 70-2-4	72
150172003	Z1 - 70-1-3	68
	Z2 - 70-2-3	72
150173003	Z1 - 70-1-4-1	68
	Z2 - 70-2-4-1	72
150174000	Z1 - 70-1-5	68
	Z2 - 70-2-5	72
150179002	Z1 - 70-1-7-1	68
	Z2 - 70-2-7-1	72
150180001	Z1 - 70-1-8	68
	Z2 - 70-2-8	72
150182000	Z1 - 70-1-9	68
	Z2 - 70-2-9	72
150188009	Z2 - 70-2-11-1	72
150189109	Z1 - 70-1-1	68
	Z2 - 70-2-1	72
150396001	S - 50-10	38
150538009	E - 51	14
150553003	P - 35	32
	T - 2	44
150556001	N - 15	30
	W - 23	54
150561000	Z1 - 91-1	66
150562000	M1 - 70-1	24
150563000	Z1 - 91-2	66
150564000	M2 - 70-3	26
150566000	M2 - 70-2	26
150567000	Z2 - 91-3	72
150763001	Z2 - 50-1	70
150764001	M3 - 47-1	28
	Z2 - 50-2	70
150765001	Z2 - 50-3	70
150766001	M3 - 47-4	28
150767001	Z2 - 50-4	70
150768001	M3 - 47-2	28
150769001	Z2 - 50-5	70
150770001	M3 - 47-3	28
150771001	Z2 - 50-6	70
151018001	Q - 26	34
151074009	S - 90	40
151583009	M2 - 34-3	26
151601002	T - 56	46
	U - 7-16	48
	M1 - 52	22
	V2 - 73	52
	V2 - 81	52
151602002	S - 113-2	40
	T - 17	44
151605002	M1 - 19	22
152997001	E - 46	14
	G - 6	16
	W - 7	56
152998001	P - 30	32
153268001	X1 - 1-1-10	58
153269001	X1 - 1-1-11	58
154702001	Z1 - 22	66
156879001	K - 7-1-1	20
156880001	K - 7-2-1	20
158437009	S - 151	42
158449001	D - 48	10
158658000	X1 - 1-1-14	58

索引/INDEX/VERZEICHIS/
INDEX/INDICE

CODE	REF.NO.	Page
158660000	X1 - 1-1-16	58
159805001	T - 5	44
	T - 24	46
	T - 60	46
159830009	Z1 - 25	66
159831009	Z1 - 25	66
180515001	S - 17-2	38
180720001	R - 19-2-1	36
	R - 19-2-1	36
180721001	R - 19-2-2	36
	R - 19-2-2	36
181092001	R - 1	36
181093101	R - 7	36
181250001	P - 1	32
181969003	M1 - 46	22
181994001	D - 10	10
183038001	R - 19-1-2	36
	R - 19-1-2	36
183039001	R - 19-1-1	36
183120000	S - 150	42
183507001	R - 19-2-3	36
	R - 19-2-3	36
183702001	D - 1	10
183703001	D - 8	10
183704001	N - 1	30
183705001	N - 3	30
183706001	S - 113	40
183746001	D - 40	10
183827001	R - 6	36
183852009	A - 76	2
183880001	R - 19-1-1	36
200190001	X1 - 1-18	60
400806003	T - 34-1-5	46
403388002	D - 37	10
507142002	U - 7-12	48
511091001	T - 65	46
	Z2 - 64	72
512769001	W - 41	56
525664000	X2 - 1-12	62
500780000	X1 - 1-3-5	60
501143001	B - 5-1-2	6
	B - 5-2-2	6
501297001	S - 81	40
501517109	X1 - 1-1	58
501518009	X1 - 1-1-1	58
501519001	X1 - 1-1-2	58
501520001	X1 - 1-1-5	58
501521000	X1 - 1-1-8	58
501522000	X1 - 1-1-9	58
	X1 - 1-2-12	58
501523000	X1 - 1-1-13	58
501524000	X1 - 1-1-15	58
501525000	X1 - 1-1-17	58
501526000	X1 - 1-1-19	58
501527000	X1 - 1-1-21	58
501528000	X1 - 1-1-22	58
501529100	X1 - 1-1-23	58
501530000	X1 - 1-17-5	60
	X1 - 1-19-2	60
501531000	X1 - 1-1-24	58
501532000	X1 - 1-1-25	58
501533000	X1 - 1-1-26	58
501534000	X1 - 1-1-27	58
501535000	X1 - 1-1-28	58

CODE	REF.NO.	Page
501536000	X1 - 1-1-29	58
501537000	X1 - 1-2-7	58
501539000	X1 - 1-1-38	58
501540000	X1 - 1-1-31	58
501543009	X1 - 1-1-36	58
501547001	X1 - 1-2-3	58
	X1 - 1-3-4	60
501548000	X1 - 1-2-6	58
	X2 - 1-5-2	62
501551000	X1 - 1-3-1	60
501557000	X2 - 1-4-6	62
501574000	X1 - 1-2-4	58
501577001	X2 - 1-4-4	62
501578001	X2 - 1-6	62
501580001	X2 - 1-5	62
501581001	X2 - 1-5-1	62
501582001	X2 - 1-9	62
501695001	F - 3-1	16
	F - 3-3	16
501700001	Z1 - 92-1	66
502624001	T - 27	46
502761109	Z1 - 70-1	68
502765109	Z2 - 70-2	72
502773001	Z1 - 70-1-2	68
	Z2 - 70-2-2	72
502778002	Z1 - 70-1-6	68
502779009	Z2 - 70-2-6	72
502780001	Z1 - 70-1-7	68
502782001	Z2 - 70-2-7	72
502784009	Z2 - 70-2-11	72
502786002	Z1 - 70-1-11	68
502788009	Z2 - 70-2-12	72
504905000	X1 - 1-17-3	60
504909000	X1 - 1-1-30	58
504910000	X1 - 1-3-2	60
506701000	Z1 - 23	66
507876001	S - 134	42
511182009	T - 26-1	46
511183009	T - 26-1-1	46
511184009	T - 26-1-2	46
514145000	X1 - 1-17-2	60
516080009	Z1 - 34	66
518707140	Z1 - 28	66
518707141	Z1 - 28	66
518707142	Z1 - 28	66
518707143	Z1 - 28	66
524514000	X1 - 1-1-32	58
524515000	X1 - 1-17	60
524516000	X1 - 1-17-1	60
524517000	X1 - 1-17-4	60
524518000	X1 - 1-1-33	58
524519000	X1 - 1-19	60
524520000	X1 - 1-19-1	60
524575001	X1 - 1-2-9	58
525671001	Y - 96-1	64
525672009	Y - 96	64
529858009	X1 - 1-2	58
529859009	X1 - 1-3	60
529860009	X1 - 1-3-6	60
531131009	Z1-25	66
531803009	X1 - 1-2-2	58
531804000	X1 - 1-2-1	58
531808001	A - 6	2

brother

ブラザー工業株式会社

〒467 名古屋市瑞穂区河岸一丁目1番1号
TEL (052) 824-2392代

BROTHER INDUSTRIES, LTD. NAGOYA, JAPAN

118-817
S96817-001 ①
1993, 08

Printed in Japan / Gedruckt in Japan / Imprimé au Japon / Impreso en Japon

From the library of: Superior Sewing Machine & Supply LLC